

GTD-5100F Explosion Proof Type Sampling Oxygen & Toxic Gas Detector

| Continuous detection of toxic gases and oxygen gas in explosion hazardous area with flame proof structure | Self diagnosis function with built-in Microprocessor |
 | Easy replacement with a cartridge type sensor | Digital flow sensor to maintain regular flow rate | Fast response of gas leakage with a high efficient pump inside |
 | Superior performance for detecting gases below TLV | Stable quality and proved detection principle for service life | Auto calibration and program setting with magnet bar on FND display board | 4-Digit digital gas concentration display | 4-20mA (Current source or Sink) output signal | Easy configuration of monitoring by RS-485 Modbus (Isolated) Serial data communication (Option) | 3-Wire Type | 2-stage alarm, 1-trouble display and relay contact output | Calibration and maintenance by one-man

IMAGE



DIMENSION (Unit : mm)

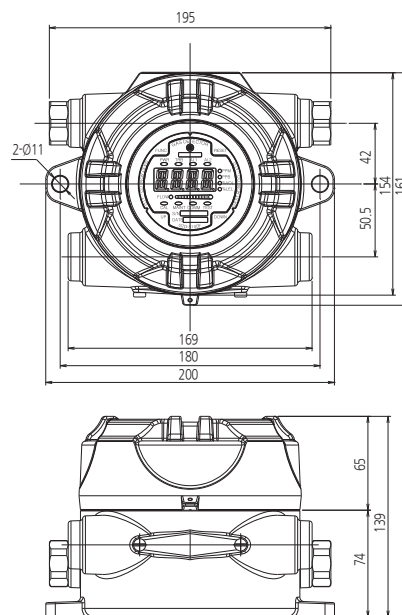

ACCESSORIES



Cable Gland



Male Connector



Micro Filter



RS-485 module



Mounting Bracket

SPECIFICATION

※ Specifications are subject to be changed without prior notice.

EXPLOSION PROOF & SAMPLING TYPE OXYGEN & TOXIC GAS DETECTOR	
Model	GTD-5100F
Measuring gas	O ₂ / Toxic gases(CO, Cl ₂ , NH ₃ & etc)
Measuring type	Auto Sampling type
Measuring method	Semiconductor cell, Electrochemical cell
measuring	Refer to Toxic Gas Measuring Range
Response time	< 45sec / 90% scale
Accuracy	±3% / Full Scale
Parameter control	Non intrusive control with a Magnet bar (calibration, maintenance, alarm setting)
Operation mode display	Alarm / Trouble LED , Flow rate
Measuring value display	FND Display(4-Digit)
Alarm signal output	2A@30VDC, 0.5A@125VAC (resistive load) / 3-SPST relay contact(2stage alarm, 1 trouble)
Output signal	Analog output : 4-20mA DC Digital output : RS-485 Modbus(Optional)
Sampling method	Diaphragm Pump
Sampling line	OD 1/4 "(Standard)
Flow rate	0 - 1000 ml/min max
Conduit connection	Standard : PF 3/4" Option : NPT 1/2", NPT3/4", M20 x 1.5P, M25 x 1.5P
Mounting type	Wall mount
Operating temperature	-20°C ~ + 60°C
Operating humidity	5 to 99% RH (Non-condensing)
Material	ALDC
Dimensions	195(W) x 139(H) x 154(D)mm
Weight	4kg
CERTIFICATION	
KCs	Ex d IIC T6 CE Refer to website