

General Specifications

Models AE100MG/MN/MH/SC, AE200MG/MN/MH/SC and AE300MG/MN Integral Type, Model AE14 Converter, Models AE100DG/DN/DH, AE200DG/DN/DH and AE300DG/DN Magnetic Flowmeter

ADMAG AE

GS 01E07A00-01E

AE100/200/300[Style:S2], AE14[Style:S1]

ADMAG AE is the Advanced Engineering designed magnetic flowmeter, evolved from the field proven ADMAG series. ADMAG AE has a dual compartment housing providing ease of wiring while isolating the electronics from the environment. ADMAG AE continues the use of dual frequency excitation, which provides quick response and noise free output. ADMAG AE excitation method and a ceramic lining allow this magnetic flowmeter to be applied to an even greater range of applications.



FEATURES

- Fast response and high stability by our unique Dual Frequency Excitation method.
- High Accuracy, 0.5% of flowrate.
- Dual compartment housing separates the wiring section from the electronics and protects the electronics from corrosive environments.
- AC/DC power supply common use (100/200V).
- Commonly available 4-conductor cables used for 24V DC version.
- High visibility backlit LCD for easy operation.
- 99.9% ultra high purity alumina ceramic lining.
- An integral leak-proof Pt Alumina cermet electrode is used on flow tubes with ceramic liners.
- Conform to Pressure Equipment Directive 97/23/EC

STANDARD SPECIFICATIONS

Magnetic Flow Converter for AE100MG/MN/SC/MH, AE200MG/MN/SC/MH, AE300MG/MN; AE14

Note 1: For models with no indicator, a hand-held terminal is necessary to set parameters.

Note 2: Pulse output, status output and alarm output use common terminals, therefore, these functions are not available at the same time.

Note 3: Please refer to GS01E07F01-00 Fieldbus communication type/(FB).

Excitation method: Dual frequency excitation

Output Signal(Note 3):

Current Output: 4 to 20 mA DC (Load resistance 750Ω maximum).

Transistor Contact Output(Open-collector):

Pulse, alarm or status output selected by parameter setting. Contact rating: 30 V DC (OFF), 200 mA (ON).

Communication (option)(Note 3):

BRAIN or HART (Superimposed on the 4 to 20 mA DC signal)

Load Resistance: (including cable resistance)

BRAIN: 250 to 600Ω

HART: 230 to 600Ω, depending on q'ty of field devices connected to the loop (multidrop mode)

Load Capacitance: 0.22 μF maximum

Load Inductance: 3.3 mH maximum

Distance from Power Line:

15 cm(0.6 ft) or more (Parallel wiring should be avoided.)

Input Impedance of Receiver Connected to the Receiving Resistance: 10kΩ or larger (at 2.4 kHz)

Maximum Cable Length:

2 km (6500 ft) (when polyethylene-insulated PVC-sheathed control cables (CEV cables) are used)

Note: HART is a registered trademark of the HART Communication Foundation.

Instantaneous Flow Rate Display Function:

Flow rate can be displayed either in engineering units or in percent of span. (for models with indicator)

Totalizer Display Function:

Totalized volume in any engineering unit can be displayed by setting a totalizing factor. (for models with indicator)

Damping Time Constant(Note 1):

Settable from 0.1 second to 200 seconds (63% response time).

Span Setting Function(Note 1):

Volumetric flow setting is available by setting volume unit, time unit, flow rate value and flow tube size.

Volume Unit: gallon(US), m³, l(litre), cm³, barrel(=158.987L)

Velocity Unit: ft, m

Time Unit: sec., min., hour, day

Flow Tube Size: inch, mm

Pulse Output Function(Note 2), (Note 3):

Scaled pulse can be output by setting a pulse factor.

Pulse Width: Duty 50% or fixed pulse width (0.5, 1, 20, 33, 50, or 100 ms) - user selectable.

Output Rate: 0.0001 to 1000pps (when pulse output function is selected.)

Status Output Function(Note 2), (Note 3):

One of the following is selected by parameter setting.

- **Auto 2 Ranges Status Output:**

Indicates the selected range for automatic dual range function.

- **Forward and Reverse Status Output:**

Indicates the flow direction for forward and reverse flow measurement mode.

- **Totalization Status Output:**

Indicates that the internal totalized value exceeds the set value.

- **Low Limit Alarm:**

Indicates that flow rate is under the low limit set value.

Alarm Output Function(Note 2), (Note 3):

Indicates that an alarm occurs (Normal Close Fixed).

Self Diagnostics Function(Note 1):

Converter failure, flow tube failure, erroneous setting, etc. can be diagnosed and displayed.

Data Security During Power Failure:

Data storage by EEPROM - no back-up battery required.

Electrical Connection:

ANSI 1/2NPT female, DIN Pg13.5 female, ISO M20×1.5 female, JIS G1/2 female.

Terminal Connection: M4 size screw terminal.

Case Material: Aluminum alloy.

Coating: Polyurethane corrosion-resistant coating. Cover; Deep sea moss green (Munsell 0.6GY3.1/2.0) Case; Frosty white (Munsell 2.5Y8.4/1.2)

Degrees of protection:

IP67, NEMA 4X, JIS C0920 water tight protection

Mounting (AE14): 2-inch pipe mounting

■ **Magnetic Flow Tube for AE100MG/MN/SC/MH and AE200MG/MN/SC/MH, AE300MG/MN; AE100DG/DN/DH, AE200DG/DN/DH, AE300DG/DN**

Protection: IP67, NEMA 4X, JIS C0920 water tight type

Size:

• **General Purpose Type**

Lining	PFA	Ceramic	Polyurethane
Size in mm (inch)	2.5(0.1), 5(0.2), 10(0.4), 15(0.5), 25(1), 40(1.5), 50(2), 65(2.5), 80(3), 100(4), 125(5), 150(6), 200(8), 250(10), 300(12), 350(14), 400(16)	2.5(0.1), 5(0.2), 10(0.4), 15(0.5), 25(1), 40(1.5), 50(2), 80(3), 100(4), 150(6), 200(8)	25(1), 40(1.5), 50(2), 80(3), 100(4), 150(6), 200(8), 250(10), 300(12), 350(14), 400(16)

T01.EPS

• **Explosion Proof Type**

Lining	PFA	Ceramic
Size in mm (inch)	2.5(0.1), 5(0.2), 10(0.4), 15(0.5), 25(1), 40(1.5), 50(2), 65**(2.5), 80(3), 100(4), 125**(5), 150(6), 200(8), 250(10)*, 300(12)*, 350(14)*, 400(16)*	2.5(0.1), 5(0.2), 10(0.4), 15(0.5), 25(1), 40(1.5), 50(2), 80(3), 100(4), 150(6), 200(8)

T02.EPS

* 250 to 400mm are only for CENELEC ATEX or SAA.

** 65 and 125mm of PFA lining are only for CENELEC ATEX.

• **Sanitary Type**

Lining	PFA
Size in mm(inch)	25(1), 40(1.5), 50(2), 65(2.5), 80(3), 100(4)

T03.EPS

* 15 and 125mm flow tubes are available on request.

Coating:

Terminal box (AE***D): Polyurethane corrosion-resistant coating. Cover; Deep sea moss green (Munsell 0.6GY3.1/2.0) Case; Frosty white (Munsell 2.5Y8.4/1.2)

Body:

Size 2.5 to 100 mm(0.1 to 4 in.): No coating (Stainless steel surface)
Size 125 to 400 mm(5 to 16 in.): Polyurethane corrosion-resistant coating. Frosty white (Munsell 2.5Y8.4/1.2)

Flow Tube Material:

Size 2.5 to 15 mm(0.1 to 0.5 in.)
Housing: Stainless steel (SCS11)
Flange (15 mm(0.5 in.) only): Stainless steel (SUS304)
Pipe: Stainless steel (SCS13) or Alumina ceramic (99.9%)
Terminal box : Aluminum alloy (AE***D)
Size 25 to 100 mm(1 to 4 in.)
Housing: Stainless steel (SUS304)
Flange: Stainless steel (SUS304)
Pipe: Stainless steel (SUS304)* or Alumina ceramic (99.9%)
Terminal box : Aluminum alloy (AE***D)
Size 125 to 400 mm(5 to 16 in.)
Housing: Carbon steel
Flange: Carbon steel
Pipe: Stainless steel (SUS304)* or Alumina ceramic (99.9% — Sizes 150 and 200 mm only)
Terminal box : Aluminum alloy (AE***D)

* For PFA or Polyurethane lining

Wetted Part Material:

Lining: Fluorocarbon PFA*, Alumina ceramic, Polyurethane.
* PFA is FDA approved material.
Electrode: Stainless steel (SUS316L), Hastelloy C (equivalent to Hastelloy C-276), Titanium, Tantalum, Platinum-Iridium, Platinum-alumina cermet only for ceramic lining.
* For sanitary type, SUS316L only
Earth Ring/Earth Electrode: Stainless steel (SUS316), Hastelloy C (equivalent to Hastelloy C-276), Titanium, PFA lining + Earth electrodes (Tantalum, Platinum-Iridium)
Gasket: • VALQUA#7020 : Fluoro resin with filler (between flow tube body and earth ring; for ceramic lining)
• VALQUA#4010 : Fluoro rubber, viton (between flow tube body and earth ring; for optional code /FRG)
• Non-asbestos joint sheet sheathed with fluoro resin (between earth ring and process flange; for optional code /BCF or /BSF)
• Chloroprene rubber (between earth ring and process flange; for optional code /BCC or /BSC)
• EPDM, ethylene propylene rubber (for sanitary type)
* Other gaskets between flow tube body and earth ring;
• VALQUA#7026 : corrosion resistance gasket (Fluoro resin with carbon)
• VALQUA#4010 (Mixing#RCD970) :Alkali resistance gasket for PVC piping (Fluoro rubber)
• VALQUA#4010 (Mixing#RCD470) : Acid resistance gasket for PVC piping (Fluoro rubber)-
Contact Yokogawa office. (Refer to TI 1E6A0-06E.)

Union Joint: Stainless steel (SUS316L) for ceramic lining size 10 mm(0.4in.) or less.*
 * Contact YOKOGAWA office if PVC Union Joints are required.

Ferrule (for sanitary type): SCS13

Electrode Construction:

• General Purpose/Ex-proof Type

PFA, Polyurethane Lining: External insertion type.
 Ceramic Lining: Integral type.

• Sanitary Type

Internal insertion type
 * Only PFA lining is available for sanitary type.

Grounding:

100Ω or less

* In case of TIIS(JIS) Flameproof type, JIS Class C (10Ω or less) or JIS Class A(10Ω or less)

Electrical Connection(AE***D):

ANSI 1/2NPT female, DIN Pg13.5 female,
 ISO M20×1.5 female, JIS G1/2 female.

Note: Hastelloy is a registered trademark of Haynes International Inc.

■ HAZARDOUS AREA CLASSIFICATION

(Ex-proof Fieldbus communication type is available only for CENELEC ATEX, FM and TIIS (former JIS))

FM:

* AE100/200MN, AE100/200DN

- Explosion proof for Class I, Division 1, Groups A, B, C & D. Dust-ignitionproof for Class II/III, Division 1, Groups E, F & G. Intrinsically safe (electrode) for Class I, Division 1, Groups A, B, C & D.
 Electrode Circuit Vmax: 250 V ac/dc
 Temp. Class. T6
 Enclosure: NEMA 4X

- Nonincendive for Class I, Division 2, Groups A, B, C & D; Suitable for Class II, Division 2, Groups F & G; Class III, Division 1 and 2.
 Intrinsically safe (electrode) for Class I, Division 1, Groups A, B, C & D.
 Electrode Circuit Vmax: 250 V ac/dc
 Excitation Circuit: 130 Vp 72/75 Hz
 Temp. Class. T5
 Enclosure: NEMA 4X

* AE14

- Explosion proof for Class I, Division 1, Groups A, B, C & D. Dust-ignitionproof for Class II/III, Division 1, Groups E, F & G.
 Temp. Class. T6
 Enclosure: NEMA 4X
 Installation shall be in accordance with the manufacturer's instructions and the National Electric Code, ANSI/NFPA-70.
- Nonincendive for Class I, Division 2, Groups A, B, C & D; Suitable for Class II, Division 2, Groups F & G; Class III, Division 1 and 2.
 Temp. Class. T5
 Enclosure: NEMA 4X

* Installation shall be in accordance with the manufacturer's instructions and the National Electric Code, ANSI/NFPA-70.

CENELEC ATEX (KEMA):

* AE100/200/300MN

No. KEMA 02ATEX2022

Group, category: II 2G
 EEx dme[ia]IIC T6...T3
 Electrode Circuit Um=250 V ac/dc
 Excitation Circuit: 130Vpeak max., 72/75 Hz, 0.27A max.

Temp. Class.	T6	T5	T4	T3
Max. Process Temp.	+70	+85	+120	+130°C
Amb. Temp:	+60°C Max.			

* AE100/200/300DN

No. KEMA 02ATEX2022

Group, category: II 2G
 EEx dme[ia]IIC T6...T3
 Electrode Circuit Um=250 V ac/dc
 Excitation Circuit: 130 Vpeak max., 72/75 Hz, 0.27A max.

Temp. Class.	T6	T5	T4	T3
Max. Process Temp.	+70	+85	+120	+150°C
Amb. Temp:	+60°C Max.			

* AE14

No. KEMA 02ATEX2022

Group, category: II 2G
 EEx d IIC T6
 Amb. Temp: +60°C Max.

CSA:

* AE100/200MN

- Explosion proof for Class I, Division 1, Groups B, C & D. Dust-ignitionproof for Class II/III, Division 1, Groups E, F & G. Intrinsically safe (electrode) for Class I, Division 1, Groups A, B, C & D
 Electrode Circuit Vmax: 250 V ac/dc

Temp. Class.	T6	T5	T4
Process Temp.	70	85	120°C

 Enclosure: Type 4
- Nonincendive for Class I, Division 2, Groups A, B, C & D; Suitable for Class II, Division 2, Groups F & G; Class III, Division 1.
 Intrinsically safe (electrode) for Class I, Division 1, Groups A, B, C & D.
 Electrode Circuit Vmax: 250 V ac/dc
 Excitation Circuit: 130 Vp 72/75 Hz, 11 Vmax

Temp. Class.	T5	T4
Process Temp.	85	120°C

 Enclosure: Type 4

* AE100/200DN

- Explosion proof for Class I, Division 1, Groups C & D. Dust-ignitionproof for Class II/III, Division 1, Groups E, F & G. Intrinsically safe (electrode) for Class I, Division 1, Groups A, B, C & D.
 Electrode Circuit Vmax: 250 V ac/dc

Temp. Class.	T6	T5	T4	T3
Process Temp.	70	85	120	150°C

 Enclosure: Type 4
- Nonincendive for Class I, Division 2, Groups A, B, C & D; Suitable for Class II, Division 2, Groups E, F & G; Class III, Division 1.
 Intrinsically safe (electrode) for Class I, Division 1, Groups A, B, C & D.
 Electrode Circuit Vmax: 250 V ac/dc
 Excitation Circuit: 130 Vp 72/75 Hz, 11 VA max.

Temp. Class.	T5	T4	T3
Process Temp.	85	120	150°C

 Enclosure: Type 4

* AE14

- Explosion proof for Class I, Division 1, Groups B, C & D. Dust-ignitionproof for Class II/III, Division 1, Groups E, F & G.
 Temp. Class. T6
 Enclosure: Type 4
- Nonincendive for Class I, Division 2, Groups A, B, C & D; Suitable for Class II, Division 2, Groups E, F & G; Class III, Division 1.
 Temp. Class. T5
 Enclosure: Type 4

SAA:

*** AE100/200/300MN**

SA Certificate No.: AUS Ex 3210X
 Type of Protection: Ex dm[ia]IIC T6 IP67
 Electrode Circuit Um: 250 V ac/dc
 Excitation Circuit: 130 Vp 72/75 Hz
 Temp. Class. T6 T5 T4
 Process Temp. 70 85 120°C

*** AE100/200/300DN**

SA Certificate No.: AUS Ex 3210X
 Type of Protection: Ex dm[ia]IIC T6 IP67
 Electrode Circuit Um: 250 V ac/dc
 Excitation Circuit: 130 Vp 72/75 Hz
 Temp. Class. T6 T5 T4 T3
 Process Temp. 70 85 120 150°C

*** AE14**

SA Certificate No.: AUS Ex 3210X
 Type of Protection: Ex d IIC T6 IP67

TIIS (former JIS):

*** AE100/200SC**

- Construction : Exde[ia] II CT4X
 : Converter, Terminal box; Explosion proof
 Flow Tube ; Increased Safety
 Signal Circuit; Intrinsically Safety (ia)
 : Ignition and Explosion Class of gas or
 vapour ; II CT4X
 - Ambient Temperature : -10 to 60°C*
 - Fluid Temperature : 120°C or less
 - Grounding : JIS Class C(10Ω or less) or JIS Class A
 (10Ω or less)
- * In case the ambient temperature exceeds 50°C, use
 heat-resistant cables with maximum allowable
 temperature of 70°C or above.

■ STANDARD PERFORMANCE

AE*MG/MN/SC/MH, AE***DG/DN/DH+AE14 (up to 30
 m cable)**

**Accuracy(Note 3):
 PFA and Ceramic Lining**

Size in mm (inch)	Span in m/s (ft/s)	Accuracy
2.5 to 15 (0.1 to 0.5)	0.3 to 1 (1 to 3)	0.5% of span
	1 to 10 (3 to 33)	0.25% of span (at indications below 50% of span)
		0.5% of rate (at indications 50% of span or more)
25 or larger (1)	0.3 to 1 (1 to 3)	0.25% of span (at indications below 50% of span)
		0.5% of rate (at indications 50% of span or more)
	1 to 10 (3 to 33)	0.1% of span (at indications below 20% of span)
		0.5% of rate (at indications 20% of span or more)

T04.EPS

Polyurethane Lining

Size in mm (inch)	Span in m/s (ft/s)	Accuracy
25 or larger (1)	0.3 to 1 (1 to 3)	0.5% of span
	1 to 10 (3 to 33)	0.25% of span (at indications below 50% of span)
		0.5% of rate (at indications 50% of span or more)

T05.EPS

Repeatability: 0.1% of flowrate (minimum 1 mm/s)

Maximum Power Consumption: 12.5W

Insulation Resistance (AE*MG/MN/MH, AE14):**

- 100MΩ between power terminals and ground terminal at 500 V DC.
- 100MΩ between power terminals and each output terminal at 500 V DC.
- 20MΩ between each output terminal and ground terminal at 100V DC.

Withstand Voltage (AE*MG/MN/MH, AE14):**

1500 V AC between power terminals and ground terminal for 1 minute.

⚠ CAUTION

When performing the Voltage Breakdown Test, Insulation Resistance Test or any unpowered electrical test, wait 10 seconds after the power supply is turned off before removing the housing cover. Be sure to remove the Short Bar at terminal "G". After testing, return the Short Bar to its correct position. Screw tightening torque should be 1.18N-m(0.88ft-lb) or more, because the G-terminal is thought as a protective grounding and should conform to the Safety Requirements.

Safety Requirement Standards:

IEC1010, EN61010

EMC Conformity Standards:

EN61326
 EN61000-3-2, EN61000-3-3
 AS/NZS 2064

Pressure Equipment Directive:

Module : H
 Type of Equipment : Piping
 Type of Fluid : Liquid and Gas
 Group of Fluid : 1 and 2

General Purpose / Explosion Proof

MODEL	DN (mm)*	PS (MPa)*	PS-DN (MPa-mm)	CATEGORY**
AE102MG/MN/SC AE102DG/DN	2.5	4	10	Article 3, *** paragraph 3
AE105MG/MN/SC AE105DG/DN	5	4	20	Article 3, *** paragraph 3
AE110MG/MN/SC AE110DG/DN	10	4	40	Article 3, *** paragraph 3
AE115MG/MN/SC AE115DG/DN	15	4	60	Article 3, *** paragraph 3
AE202MG/MN/SC AE202DG/DN	25	4	100	Article 3, *** paragraph 3
AE204MG/MN/SC AE204DG/DN	40	4	160	II
AE205MG/MN/SC AE205DG/DN	50	4	200	II
AE206MG/MN/SC AE206DG/DN	65	2	130	II
AE208MG/MN/SC AE208DG/DN	80	2	160	II
AE210MG/MN/SC AE210DG/DN	100	2	200	II
AE212MG/MN/SC AE212DG/DN	125	2	250	II
AE215MG/MN/SC AE215DG/DN	150	2	300	II
AE220MG/MN/SC AE220DG/DN	200	2	400	III
AE325MG/MN/SC AE325DG/DN	250	2	500	III
AE330MG/MN/SC AE330DG/DN	300	2	600	III
AE335MG/MN/SC AE335DG/DN	350	1	700	II
AE340MG/MN/SC AE340DG/DN	400	1	800	III

T22.EPS

Sanitary

MODEL	DN (mm)*	PS (MPa)*	PS-DN (MPa-mm)	CATEGORY**
AE202MH AE202DH	25	1	25	Article 3, *** paragraph 3
AE204MH AE204DH	40	1	40	I
AE205MH AE205DH	50	1	50	I
AE206MH AE206DH	65	1	65	I
AE208MH AE208DH	80	1	80	I
AE210MH AE210DH	100	1	100	I

T22.EPS

- * PS: Maximum allowable pressure for Flow Tube
DN: Nominal size
- ** Referred to Table 6 covered by ANNEX II of EC Directive on Pressure Equipment Directive 97/23/EC)
- *** AE102MG/MN/SC/AE102DG/DN to AE202MG/MN/SC/AE202DG/DN, and AE202MH/AE202DH are not attached CE mark of PED because they do not come under CE marking of PED.

■ NORMAL OPERATING CONDITIONS

Ambient Temperature: -10 to 60°C (14 to 140°F)

Ambient Humidity: 5 to 95%RH (no condensation)

Power Supply Voltage: -A1; Range 80 to 264 V AC, 47 to 63Hz/100 to 130 VDC, -D1; Range 20.4 to 28.8 V DC(except /FB)

Supplied Power and Max. Cable Length for 24 V DC version:

Allowable cable length m(ft)

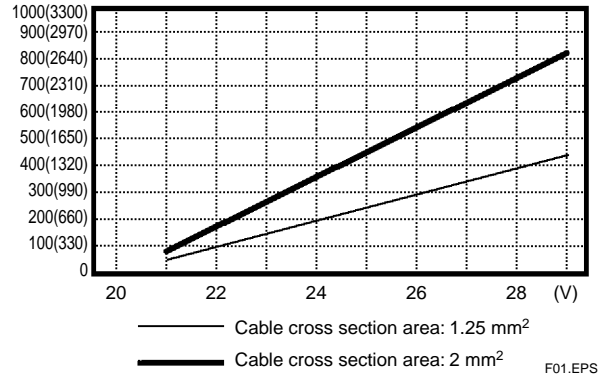

F01.EPS

Altitude at installation side: Max.2000m above sea level

Installation category based on IEC1010: II(See Note)

Pollution level based on IEC1010: 2(See Note)

Note: • The "Installation category" implies the regulation for impulse withstand voltage. It is also called the "Overvoltage category". "II" applies to electrical equipment.

• "Pollution level" describes the degree to which a solid, liquid or gas which deteriorates dielectric strength is adhering. "2" applies to normal indoor atmosphere.

Fuse: 2A, 250V(Time - Lag type)

Fluid Conductivity:

Size 15 to 200mm(0.5 to 8in.); 5µS/cm or larger

Size 2.5 to 10mm(0.1 to 0.4in.); 20µS/cm or larger

*In case that size 250 or 300mm is used for high conductivity fluid (ex. caustic soda, seawater), please use the flange type.

**Measurable Flow Rate Range:
SI Units (Size: mm, Flowrate: m³/h)**

Size	Min. Range @ 0.3m/s	Max. Range @ 10m/s
2.5	0.0054	0.1767
5	0.0213	0.7068
10	0.0849	2.8274
15	0.1909	6.361
25	0.5302	17.671
40	1.3572	45.23
50	2.1206	70.68
65	3.584	119.45
80	5.429	180.95
100	8.483	282.74
125	13.254	441.7
150	19.086	636.1
200	33.93	1,131
250	53.02	1,767.1
300	76.35	2,544.6
350	103.91	3,463
400	135.72	4,523

T06.EPS

English Units (Size: inch, Flowrate: GPM)

Size	Min. Range @ 1.0ft/s	Max. Range @ 33ft/s
0.1	0.0241	0.8031
0.2	0.0964	3.212
0.4	0.3856	12.850
0.5	0.6024	20.078
1	2.4095	80.31
1.5	5.422	180.70
2	9.638	321.2
2.5	15.06	501.9
3	21.685	722.8
4	38.56	1,285.0
5	60.24	2,007.8
6	86.74	2,891.3
8	154.21	5,140
10	240.95	8,031
12	347.0	11,565
14	472.3	15,741
16	616.9	20,560

T07.EPS

**Fluid Temperature and Pressure:
General Purpose /Explosion proof**

PFA, Polyurethane Lining (Integral Type)

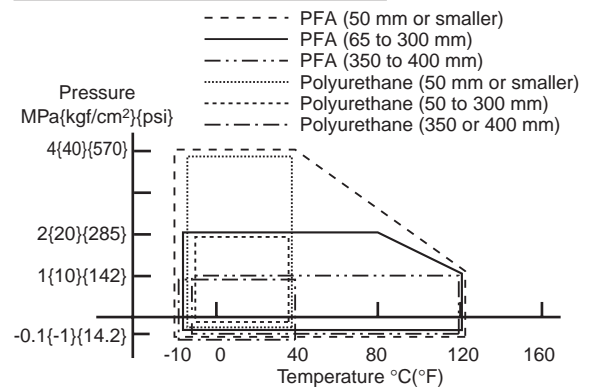

PFA, Polyurethane Lining (Remote Type)

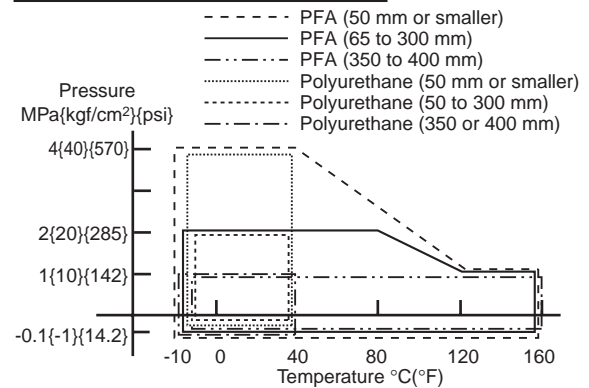

Ceramic Lining (Integral Type / Remote Type)

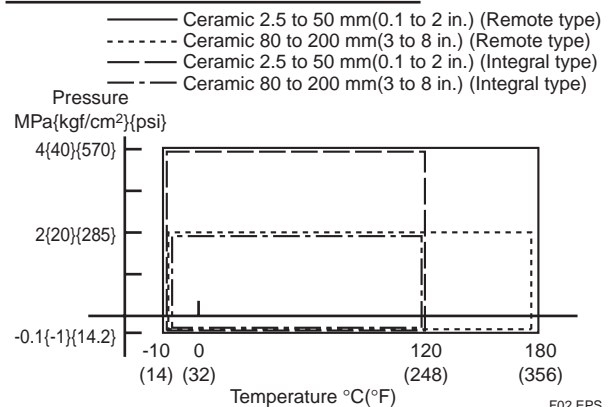

F02.EPS

Note 1: Those limits show maximum allowable fluid pressure for Flow Tube itself. Further fluid pressure should also be limited according to process connection.

Note 2: For Explosion proof type, maximum fluid pressure should be 2MPa or lower (for 350 and 400 mm, 1 MPa or lower) except CENELEC ATEX explosion proof version, and for fluid temperature refer to descriptions of "HAZARDOUS AREA CLASSIFICATION".

Sanitary

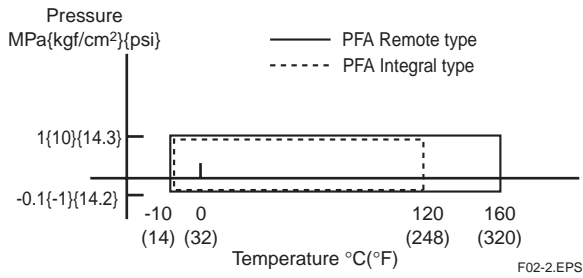

Reasonable Figures for Thermal Shock of Ceramic Lining:

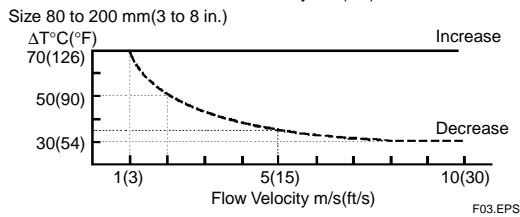
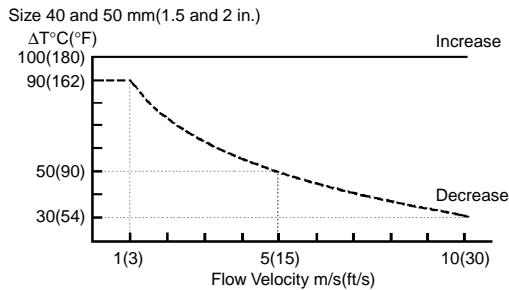
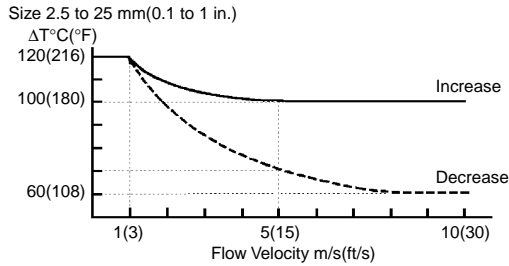

ACCESSORIES

Integral type flowmeter (AE*MG/MN/SC/MH):**

- Fuse(2A) 1
- Data sheet 1
- Unit label 1
- Centering device 1set (in case of wafer type)
- Hexagonal wrench (in case of Ex-proof) 1

Remote type converter (AE14):

- Fuse(2A) 1
- Data sheet 1
- Mounting bracket 1
- Hexagonal wrench (in case of Ex-proof) 1

Remote type flowtube (AE*DG/DN):**

- Centering device 1set (in case of wafer type)
- Hexagonal wrench (in case of Ex-proof) 1

TERMINAL CONNECTION (Note 3)

Integral Type Flowmeter:

Terminal Symbols	Description
[P+ P-]] Pulse, alarm or status output
[I+ I-]] Current output 4 to 20 mA DC
[L+ N/-]] Power supply
[Ⓧ]] Protective grounding

T08.EPS

Remote Type Converter (AE14):

Terminal Symbols	Description
[SA]] A shield
[A]] Flow signal input
[B]] B shield
[SB]] Common
[C]] Common
[EX1]] Excitation current output
[EX2]] Excitation current output
[P+ P-]] Pulse, alarm or status output
[I+ I-]] Current output 4 to 20mA DC
[L+ N/-]] Power supply
[Ⓧ]] Protective grounding

T09.EPS

Remote Type Flow Tube (AE*DG/DN/DH):**

Terminal Symbols	Description
[A]] Flow signal output
[B]] Common
[C]] Common
[EX1]] Excitation current input
[EX2]] Excitation current input
[Ⓧ]] Protective grounding (Outside of the terminal box)

T10.EPS

MODEL AND SUFFIX CODE

General Purpose/Explosion Proof, Integral Type AE100/200 series

○: Available -: Not available

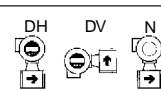

Model	Suffix Code	Description	Use								
			MG		SC		MN				
			Lining								
			A	U	C	A	C	A	C		
AE102		Size 2.5 mm (0.1in.)	○	-	○	○	○	○	○	Note 1	
AE105		Size 5 mm (0.2in.)	○	-	○	○	○	○	○	Note 1	
AE110		Size 10 mm (0.4in.)	○	-	○	○	○	○	○	Note 1	
AE115		Size 15 mm (0.5in.)	○	-	○	○	○	○	○	Note 1	
AE202		Size 25 mm (1in.)	○	○	○	○	○	○	○		
AE204		Size 40 mm (1.5in.)	○	○	○	○	○	○	○		
AE205		Size 50 mm (2in.)	○	○	○	○	○	○	○		
AE206		Size 65 mm (2.5in.)	○	-	-	-	-	-	-		
AE208		Size 80 mm (3in.)	○	○	○	○	○	○	○		
AE210		Size 100 mm (4in.)	○	○	○	○	○	○	○		
AE212		Size 125 mm (5in.)	○	-	-	-	-	-	-		
AE215		Size 150 mm (6in.)	○	○	○	○	○	○	○		
AE220		Size 200 mm (8in.)	○	○	○	○	○	○	○		
Use	MG	General purpose type	○	○	○	-	-	-	-	Note 4	
	MN	CENELEC,FM,CSA,SAA Ex-proof	-	-	-	-	-	-	-	Note 5	
	SC	TIIS (JIS) Flameproof	-	-	-	○	○	-	-		
Lining	-A	Fluorocarbon PFA	○	-	-	○	-	○	-		
	-U	Polyurethane	-	○	-	-	-	-	-		
	-C	Ceramic	-	-	○	-	○	-	○		
Process Connection (Note 3)	K1	JIS 10K wafer	○	○	○	○	○	○	○	Not available with 65/125mm	
	K2	JIS 20K wafer	○	○	○	○	○	○	○		
	B1	ANSI 150 wafer	○	○	○	○	○	○	○	Not available with 65/125mm	
	B2	ANSI 300 wafer	○	○	○	○	○	○	○		
	E1	DIN PN10 wafer	○	○	○	○	○	○	○	Size 200 mm(8in.) only	
	E2	DIN PN10/16 wafer	○	○	○	○	○	○	○	Note 2	
	E4	DIN PN40 wafer	○	○	○	-	-	○	○	Note 7	
	H1	JIS F12(JIS75M) wafer	○	○	○	○	○	○	○	Size 80 mm(3in.) or larger	
	J1	JIS 10K flange	○	○	-	○	-	○	-	Not available with 65/125mm	
	J2	JIS 20K flange	○	○	-	○	-	○	-		
	A1	ANSI 150 flange	○	○	-	○	-	○	-	Size 200mm (8in.)only	
	A2	ANSI 300 flange	○	○	-	○	-	○	-		
	D1	DIN PN10 flange	○	○	-	○	-	○	-	Note 2	
	D2	DIN PN16 flange	○	○	-	○	-	○	-	Note 7	
	D4	DIN PN40 flange	○	○	-	-	-	○	-	Size 80/100/150/200mm only	
	G1	JIS F12(JIS75M) flange	○	○	-	○	-	○	-	Ceramic lining, size 2.5/ 5/10mm only	
	U1	Union Joint (weld joint)	-	-	○	-	○	-	-		
	U2	Union Joint (R1/4 or R3/8)	-	-	○	-	○	-	-		
	U3	Union Joint (1/4NPT or 3/8NPT)	-	-	○	-	○	-	-		
Electrode Material	-L	Stainless Steel (SUS316L)	○	○	-	○	-	○	-	Not available with 65/125mm	
	-P	Platinum-iridium	○	-	-	○	-	○	-		
	-E	Platinum-alumina cermet	-	-	○	-	○	-	-		
	-H	Hastelloy C276 equivalent	○	-	-	○	-	○	-		
	-T	Tantalum	○	-	-	○	-	○	-		
	-V	Titanium	○	-	-	○	-	○	-		
Earth Ring/Earth Electrode Material	S	Stainless Steel (SUS316)	○	○	○	○	○	○	○	Note 6	
	P	Platinum-iridium	○	-	○	○	○	○	○	Must for ceramic, 2.5/5/10mm	
	N	None	○	○	○	○	○	○	○	Not available with 65/125mm	
	H	Hastelloy C276 equivalent	○	-	○	○	○	○	○	Note 6	
	T	Tantalum	○	-	○	○	○	○	○	Note 6	
	V	Titanium	○	-	○	○	○	○	○	Not available with 65/125mm	
Electrical Connection	J	JIS G1/2 female	○	○	○	○	○	-	-		
	A	ANSI 1/2NPT female	○	○	○	-	-	○	○		
	D	DIN Pg13.5 female	○	○	○	-	-	○	○		
	M	ISO M20×1.5 female	○	○	○	-	-	○	○		
Power Supply	-A1	80 to 264 V AC/100 to 130 V DC	○	○	○	○	○	○	○		
	-D1	20.4 to 28.8 V DC	○	○	○	○	○	○	○		
Indicator	DH	7seg.LCD(Horizontal Mounting)	○	○	○	○	○	○	○		
	DV	7seg.LCD(Vertical Mounting)	○	○	○	○	○	○	○		
	N	None	○	○	○	-	-	○	○		
Optional Code		/□ Refer to "Optional Specifications."									

T11.EPS

- Note 1: Process connection for size 2.5 to 10mm(0.1 to 0.4in.), wafer type is equal to one for 15mm(0.5in.). Provide 15mm process flanges for these flow tubes.
- Note 2: Select PN16 when requirement of PN10 for sizes 80mm(3in.) to 150mm(6in) because of same mating dimensions. Not available with 65, 125mm.
- Note 3: Flange type is available for size 15mm or larger, PFA or Polyurethane lining.
- Note 4: Select ANSI 1/2NPT female electrical connection(code A) in case of requirement of FM/CSA explosion proof type. For CENELEC ATEX explosion proof type, select ANSI 1/2NPT (code A) or ISO M20×1.5(code M) electrical connection.
- Note 5: Select JIS G1/2 female electrical connection (code J) and optional code /JF3 with /G11, /G12 in case of requirement of TIIS(JIS) Flameproof type.
- Note 6: Platinum-iridium and Tantalum earth electrodes are not available with 65, 125mm and ceramics 150, 200mm.
- Note 7: Select "PN40" when requirement of PN10, PN16, PN25 for sizes 50mm or less wafer or flange process connection because of same mating dimension. "PN40" is available for CENELEC ATEX, but not available for FM, CSA, or SAA ex-proof version.

General Purpose /Explosion Proof, Integral Type AE300 series

○: Available –: Not available

Model	Suffix Code	Description	Use			
			MG	MN	Lining	
			A	U		A
AE325 AE330 AE335 AE340	Size 250mm (10in.) Size 300mm (12in.) Size 350mm (14in.) Size 400mm (16in.)	○ ○ ○ ○	○ ○ ○ ○	○ ○ ○ ○	
Use	MG MN	General Purpose Ex-proof(CENELEC ATEX,SAA)	○ –	○ –	– ○	
Lining	-A -U	Fluorocarbon PFA Polyurethane	○ –	– ○	○ –	
Process Connection	K1 B1 E1 H1 J1 J2 A1 A2 D1 D2 G1	JIS 10K wafer ANSI 150 wafer DIN PN10 wafer JIS F12 wafer JIS 10K flange JIS 20K flange ANSI 150 flange ANSI 300 flange DIN PN10 flange DIN PN16 flange JIS F12(JIS75M) flange	○ ○ ○ ○ ○ ○ ○ ○ ○ ○ ○	○ ○ ○ ○ ○ ○ ○ ○ ○ ○ ○	– – – – ○ ○ ○ ○ ○ ○ ○	Only for size 250, 300mm Only for size 250, 300mm Only for size 250, 300mm Only for size 250, 300mm Only for size 250, 300mm Only for size 250, 300mm Only for size 250, 300mm Only for size 250, 300mm
Electrode Material	-L -P -H -T -V	Stainless Steel (SUS316L) Platinum-iridium Hastelloy C276 equivalent Tantalum Titanium	○ ○ ○ ○ ○	○ – – – –	○ ○ ○ ○ ○	Only for flange type Only for flange type Only for flange type Only for flange type
Earth Ring Material	S H V N	Stainless Steel (SUS316) Hastelloy C276 equivalent Titanium None	○ ○ ○ ○	○ – – ○	○ ○ ○ ○	Only for flange type Only for flange type
Electrical Connection	J A D M	JIS G1/2 female ANSI 1/2NPT female DIN Pg13.5 female ISO M20×1.5 female	○ ○ ○ ○	○ ○ ○ ○	– ○ ○ ○	
Power Supply	-A1 -D1	80 to 264 V AC/100 to 130 V DC 20.4 to 28.8 V DC	○ ○	○ ○	○ ○	
Indicator	DH .. DV .. N	7seg.LCD(Horizontal Mounting) 7seg.LCD(Vertical Mounting) None	○ ○ ○	○ ○ ○	○ ○ ○	Note   
Optional Code		<input type="checkbox"/> Refer to "Optional Specifications."				

T12.EPS

Remote Type Converter:

Model	Suffix Code	Description
AE14	Magnetic flow converter
Indicator	-D -N	7 seg. LCD None
Power supply	A1 D1	80 to 264VAC/100 to 130VDC 20.4 to 28.8VDC
Electrical connection	J A D M	JIS G1/2 female ANSI1/2 NPT female DIN Pg 13.5 female ISO M20×1.5 female
Optional Code		Refer to "Optional Specifications."

T13.EPS

Dedicated Signal Cable:

Model	Suffix Code	Description
AM011	Dedicated cable for magnetic flowmeter
End treatment	-0 -4	Non termination Terminated
Cable length	-L □□	Enter the length in m (Max 30m)
Style code	*A	Style A
Optional specification	/C □ ..	Number of end treatment parts

T14.EPS

Note 1: A user provided two conductor cable is required for coil excitation.

Note 2: The maximum temperature for the signal cable is 80°C(176°F).

General Purpose/Explosion Proof, Remote Type Flow Tube AE100/200 series

○: Available –: Not available

Model	Suffix Code	Description	Use					
			DG			DN		
			Lining					
			A	U	C	A	C	
AE102	Size 2.5 mm (0.1in.)	○	–	○	○	○	Note 1
AE105	Size 5 mm (0.2in.)	○	–	○	○	○	
AE110	Size 10 mm (0.4in.)	○	–	○	○	○	
AE115	Size 15 mm (0.5in.)	○	–	○	○	○	
AE202	Size 25 mm (1in.)	○	○	○	○	○	
AE204	Size 40 mm (1.5in.)	○	○	○	○	○	
AE205	Size 50 mm (2in.)	○	○	○	○	○	
AE206	Size 65 mm (2.5in.)	○	–	–	–	–	
AE208	Size 80 mm (3in.)	○	○	○	○	○	
AE210	Size 100 mm (4in.)	○	○	○	○	○	
AE212	Size 125 mm (5in.)	○	–	–	–	–	
AE215	Size 150 mm (6in.)	○	○	○	○	○	
AE220	Size 200 mm (8in.)	○	○	○	○	○	
Use	DG	General Purpose	○	○	○	–	–	Note 4
	DN	Ex-proof(CENELEC ATEX,FM,CSA,SAA)	–	–	–	○	○	
Lining	-A	Fluorocarbon PFA	○	–	–	○	–	
	-U	Polyurethane	–	○	–	–	–	
	-C	Ceramic	–	–	○	–	○	
Process Connection (Note 3)	K1	JIS 10K wafer	○	○	○	○	○	Not available with 65/125mm
	K2	JIS 20K wafer	○	○	○	○	○	
	B1	ANSI 150 wafer	○	○	○	○	○	
	B2	ANSI 300 wafer	○	○	○	○	○	
	E1	DIN PN10 wafer	○	○	○	○	○	Not available with 65/125mm Size 200 mm(8in.) only
	E2	DIN PN10/16 wafer	○	○	○	○	○	
	E4	DIN PN40 wafer	○	○	○	○	○	Note 2 Note 6
	H1	JIS F12(JIS75M) wafer	○	○	○	○	○	
	J1	JIS 10K flange	○	○	–	○	–	Size 80 mm(3in.) or larger
	J2	JIS 20K flange	○	○	–	○	–	
	A1	ANSI 150 flange	○	○	–	○	–	
	A2	ANSI 300 flange	○	○	–	○	–	Not available with 65/125mm
	D1	DIN PN10 flange	○	○	–	○	–	
	D2	DIN PN16 flange	○	○	–	○	–	Size 200mm (8in.)only Note 2
D4	DIN PN40 flange	○	○	–	○	–		
G1	JIS F12(JIS75M) flange	○	○	–	○	–	Note 6 Size 80/100/150/200mm only	
U1	Union Joint (weld joint)	–	–	○	–	○		
U2	Union Joint (R1/4 or R3/8)	–	–	○	–	○	Ceramic lining, size 2.5/ 5/10mm only	
U3	Union Joint (1/4NPT or 3/8NPT)	–	–	○	○	○		
Electrode Material	-L	Stainless Steel (SUS316L)	○	○	–	○	–	Not available with 65/125mm
	-P	Platinum-iridium	○	–	–	–	–	
	-E	Platinum-alumina cermet	–	–	○	○	○	
	-H	Hastelloy C276 equivalent	○	–	–	○	–	
	-T	Tantalum	○	–	–	○	–	
	-V	Titanium	○	–	–	○	–	
Earth Ring/Earth Electrode Material	S	Stainless Steel (SUS316)	○	○	○	○	○	Note 5
	P	Platinum-iridium	○	–	○	○	○	
	N	None	○	○	○	○	○	
	H	Hastelloy C276 equivalent	○	–	○	○	○	Must for ceramic, 2.5/ 5/10mm Not available with 65/125mm Note 5
	T	Tantalum	○	–	○	○	○	
	V	Titanium	○	–	○	–	○	
Electrical Connection	J	JIS G1/2 female	○	○	○	○	–	
	A	ANSI 1/2NPT female	○	○	○	○	○	
	D	DIN Pg13.5 female	○	○	○	○	○	
	M	ISO M20 X1.5 female	○	○	○	○	○	
Optional Code	<input type="checkbox"/>	Refer to "Optional Specifications."						

T15.EPS

- Note 1: Process connection for size 2.5 to 10mm (0.1 to 0.4in.), wafer type is equal to one for 15mm (0.5in.). Provide 15mm process flanges for these flow tubes.
- Note 2: Select PN16 when requirement of PN10 for sizes 80mm (3in.) to 150mm(6in.) because of same mating dimensions. Not available with 65, 125mm.
- Note 3: Flange type is available for size 15mm or larger, PFA or Polyurethane lining.
- Note 4: Select ANSI 1/2 NPT female electrical connection(codeA) in case of requirement of FM/CSA explosion proof type.
For CENELEC ATEX explosion proof type, select ANSI 1/2NPT(code A) or ISO M20× 1.5 (code M) electrical connection.
- Note 5: Platinum-iridium and tantalum electrodes are not available with 65, 125mm and ceramics 150, 200mm.
- Note 6: Select "PN40" when requirement of PN10, PN16, PN25 for sizes 50mm or less wafer or flange process connection because of same mating dimension. "PN40" is available for CENELEC ATEX, but not available for FM, CSA, or SAA ex-proof version.

General Purpose/Explosion Proof, Remote Type Flow Tube AE300 series

○: Available –: Not available

Model	Suffix Code	Description	Use		
			DG	DN	
			Lining		
			A	U	A
AE325	Size 250mm (10in.)	○	○	○
AE330	Size 300mm (12in.)	○	○	○
AE335	Size 350mm (14in.)	○	○	○
AE340	Size 400mm (16in.)	○	○	○
Use	DG	○	○	–
	DN	–	–	○
Lining	-A	○	–	○
	-U	–	○	–
Process Connection	K1	JIS 10K Wafer	○	○	–
	B1	ANSI 150 Wafer	○	○	–
	E1	DIN PN10 Wafer	○	○	–
	H1	JIS F12 Wafer	○	○	–
	J1	JIS 10K flange	○	○	○
	J2	JIS 20K flange	○	○	○
	A1	ANSI 150 flange	○	○	○
	A2	ANSI 300 flange	○	○	○
	D1	DIN PN10 flange	○	○	○
	D2	DIN PN16 flange	○	○	○
	G1	JIS F12(JIS75M) flange	○	○	○
Electrode Material	-L	○	○	○
	-P	○	–	○
	-H	○	–	○
	-T	○	–	○
	-V	○	–	○
Earth Ring Material	S	○	○	○
	H	○	–	○
	V	○	–	○
	N	○	○	○
Electrical Connection	J	○	○	–
	A	○	○	○
	D	○	○	○
	M	○	○	○
Optional Code	/□	Refer to "Optional Specifications."			

T16.EPS

Sanitary, Integral Type

Model	Suffix code	Description
AE202	Size 25 mm(1in.)
AE204	Size 40 mm(1.5in.)
AE205	Size 50 mm(2in.)
AE206	Size 65 mm(2.5in.)
AE208	Size 80 mm(3in.)
AE210	Size 100 mm(4in.)
Use	MH
Lining	-A
Process Connection	C1
Electrode Material	-L
Earth Ring	N
Electrical Connection	J
	A
	D
	M
Power Supply	-A1
	-D1
Indicator	DH
	DV
	N
Optional Code	/□	Refer to "Optional Specifications."

T17.EPS

Sanitary, Remote Type Flow Tube:

Model	Suffix code	Description
AE202	Size 25 mm(1in.)
AE204	Size 40 mm(1.5in.)
AE205	Size 50 mm(2in.)
AE206	Size 65 mm(2.5in.)
AE208	Size 80 mm(3in.)
AE210	Size 100 mm(4in.)
Use	DH
Lining	-A
Process Connection	C1
Electrode Material	-L
Earth Ring	N
Electrical Connection	J
	A
	D
	M
Optional Code	/□	Refer to "Optional Specifications."

T18.EPS

Optional Specifications

○: Available –: Not available

Item	Specification	Applicable Model								Code	
		General		Ex-proof				Sanitary			
		AE***MG	AE14	AE***DG	AE***MN	AE***SC	AE14	AE***DN	AE***MH		AE***DH
Waterproof Gland	Waterproof glands are attached to all wiring ports. For JIS G1/2 only.	○	○	○	–	–	–	–	○	○	/ECG
Waterproof Gland with Union Joint	Waterproof glands (union joint) are attached to all wiring ports. For JIS G1/2 only.	○	○	○	–	–	–	–	○	○	/ECU
Gaskets for PVC pipe	Gaskets are attached between earth ring and flow tube. (Not available with 65, 125mm)	○	–	○	○	○	–	○	–	–	/FRG
DC Noise Suppression	Eliminating DC Noise (Size 15mm(0.5in.) or larger: Conductivity 50μS/cm or higher.)	○	○	–	○	○	○	–	○	○	/ELC
Lightning Protector	Built-in Lightning Protector(Only for 24VDC version)	○	○	–	○	○	○	–	○	○	/A
BRAIN Communication(Note 1)	Digital Communication with BRAIN protocol	○	○	–	○	○	○	–	○	○	/BR
HART Communication(Note 1)	Digital Communication with HART protocol	○	○	–	○	–	○	–	○	○	/HART
FOUNDATION Fieldbus Communication (Note 1)	Digital Communication with FOUNDATION Fieldbus protocol (except 24 VDC version)	○	○	–	Note 7	○	Note 7	○	○	–	/FB
PID/LM function for FOUNDATION Fieldbus (Note 6)	PID control function and Link Master function	○	○	–	Note 7	○	Note 7	○	○	–	/LC1
Epoxy Coating	Coating is changed to epoxy coating.	○	○	○	○	○	○	○	–	–	/EPF
High Anti-corrosion Coating	Coating is changed to three-layer coating(Urethane coating on two-layer Epoxy coating)	○	○	○	○	○	○	○	–	–	/X2
Material Certificate(Note 2)	Reproduced material certificate for pipe, electrode, earth ring, mini-flange and flange (depends on spec.).	○	–	○	○	○	–	○	–	–	/M01
Bolt & Nut Assembly(Note 3)	Carbon steel bolts/nuts and chloroprene gaskets assembly for wafer type	○	–	○	○	○	–	○	–	–	/BCC
	Carbon steel bolts/nuts and non-asbestos PTFE-wrapped gaskets assembly for wafer type	○	–	○	○	○	–	○	–	–	/BCF
	Stainless steel bolts/nuts and chloroprene gaskets assembly for wafer type	○	–	○	○	○	–	○	–	–	/BSC
	Stainless steel bolts/nuts and non-asbestos PTFE-wrapped gaskets assembly for wafer type	○	–	○	○	○	–	○	–	–	/BSF
DHC use (for size 100 to 400mm)	Condensation proof for District Heating and Cooling use. Terminal box; urethane resin potting. Wired 30m signal cable at factory.	–	–	○	–	–	–	–	–	–	/DHC
FM Approval(Note 4)	FM Explosion proof/FM Nonincendive	–	–	–	○	–	○	○	–	–	/FF1/FN1
CENELEC ATEX Certification (KEMA Approval)	CENELEC ATEX Explosion proof	–	–	–	○	–	○	○	–	–	/KF2
CSA Certification(Note 4)	CSA Explosion proof/CSA Nonincendive	–	–	–	○	–	○	○	–	–	/CF1/CN1
SAA Certification	SAA Explosion proof	–	–	–	○	–	○	○	–	–	/SF1
TIIS(JIS) Flameproof (Note 4)(Note 5)	JIS Flameproof type	–	–	–	–	(Note 5)	–	–	–	–	/JF3
Flameproof Packing Adapter for TIIS(JIS) Flameproof (Note 5) (Only for JIS G1/2 electrical connection)	One Flameproof Packing Adapter and a blind plug are attached.(only for DC power supply)	–	–	–	–	(Note 5)	–	–	–	–	/G11
	Two Flameproof Packing Adapters are attached.(Not apply for one port wiring.)	–	–	–	–	(Note 5)	–	–	–	–	/G12
GOST Certification	Calibration Certificate for GOST (only for products produced at YMF)	○	○	○	○	–	○	○	○	○	/GOS
Silicon Rubber Gasket for sanitary type	In case of fluid temp. over 120°C (248°F), 160°C (320°F) max. (Not available with 65mm)	–	–	–	–	–	–	–	–	○	/SRG
Mirror Finished Ceramics	Mirror Finishing on the inside of ceramic tube (Rmax.<=1 micro-meter)	○	–	○	○	○	–	○	–	–	/MRR
180deg. Rotated Converter	180deg. rotated converter for reversed flow direction	○	–	–	○	○	–	–	○	–	/CRC
Oil-prohibited Use	Degreased cleansing treatment	○	–	○	○	○	–	○	–	–	/K1
Oil-prohibited Use with Dehydrating Treatment	Degreased cleansing treatment; Packing with desiccant	○	–	○	○	○	–	○	–	–	/K5
Hydrostatics Test Certificate	Test pressure depends on process connection (Test duration 10 minutes) Test result is full in NOTE of QIC.	○	–	○	○	○	–	○	–	–	/T01
Calibration Certificate	Level 2:Declaration and Calibration Equipment List	○	○	○	○	○	○	○	○	○	/L2
	Level 3:Declaration and Primary Standard List	○	○	○	○	○	○	○	○	○	/L3
	Level 4:Declaration and YOKOGAWA Measuring	○	○	○	○	○	○	○	○	○	/L4

Note 1: Either BRAIN, HART, or FOUNDATION Fieldbus communication can be selected.
 Note 2: In case of requirement of EN10204 3.1B for Material Certificate, contact Yokogawa office.
 Note 3: It is available only for JIS 10K wafer, JIS 20K wafer or ANSI 150 wafer type, not available with 65, 125, 250 or 300mm.
 Note 4: It is available only for size 2.5 to 200mm(0.1 to 8 in).
 Note 5: Select optional code /JF3 with /G11 or /G12 in case of requirement of TIIS(JIS) Flameproof type. /G11 is selectable only for DC power supply and 4-conductor cable use.
 Note 6: Optional code /LC1 is a function for Fieldbus communication. Optional code /FB must be selected together with /LC1.
 Note 7: Ex-proof Fieldbus communication is available only for CENELEC ATEX, FM and TIIS (former JIS) ex-proof version.

T19.EPS

EXTERNAL DIMENSIONS

Integral Magnetic Flowmeter

2.5 to 15mm(0.1 to 0.5in.) Wafer Type

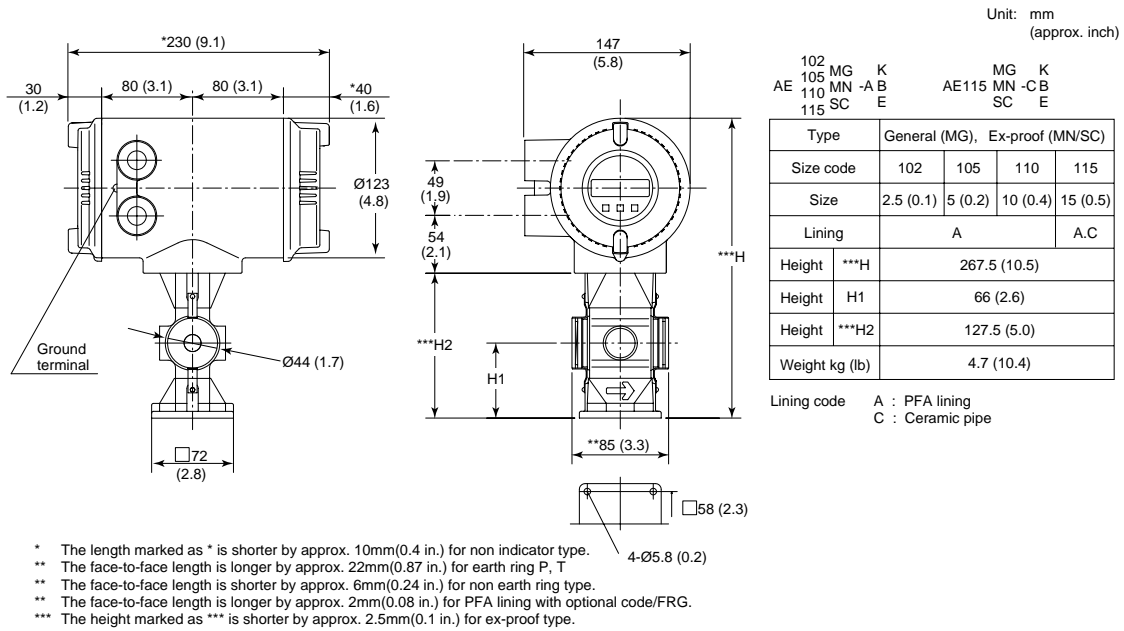

F04.EPS

2.5 to 10mm(0.1 to 0.4in.) Union Joint Type

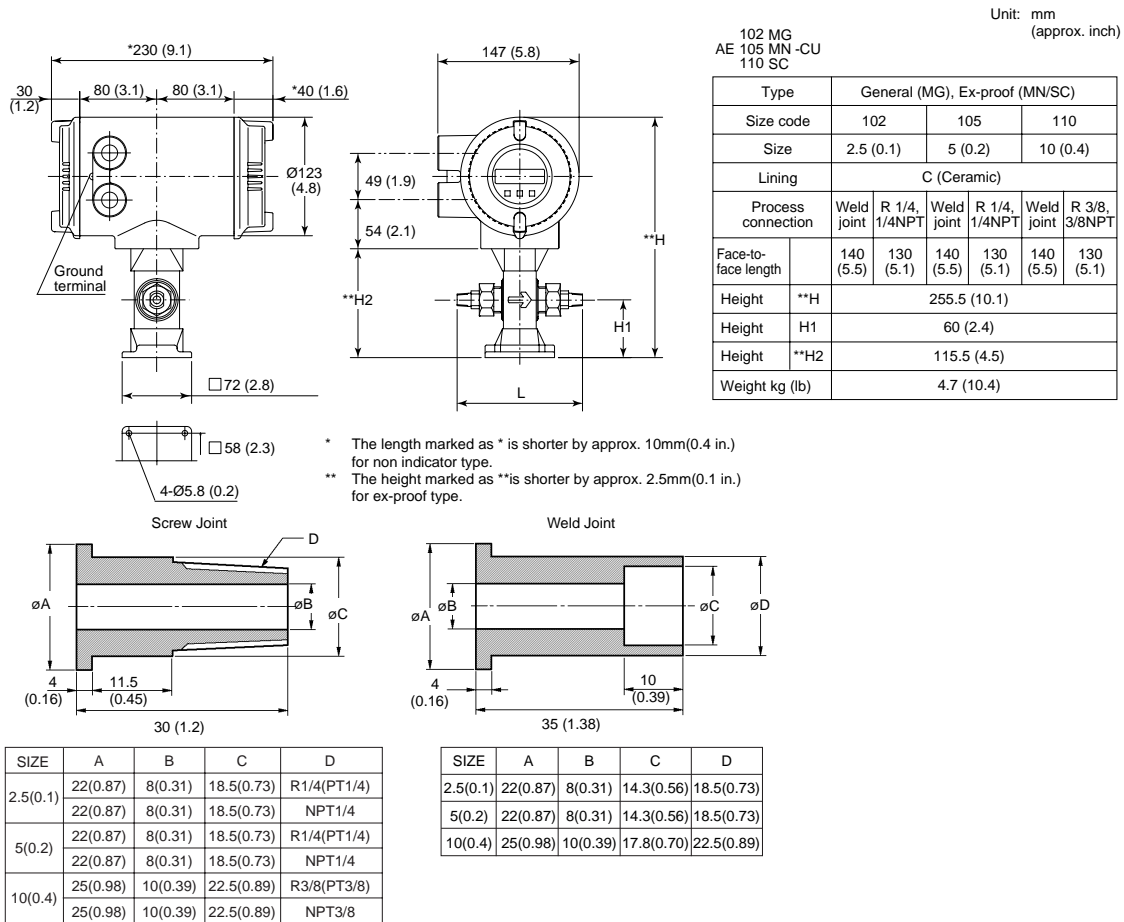

F05.EPS

25 to 100mm(1 to 4in.) Wafer Type

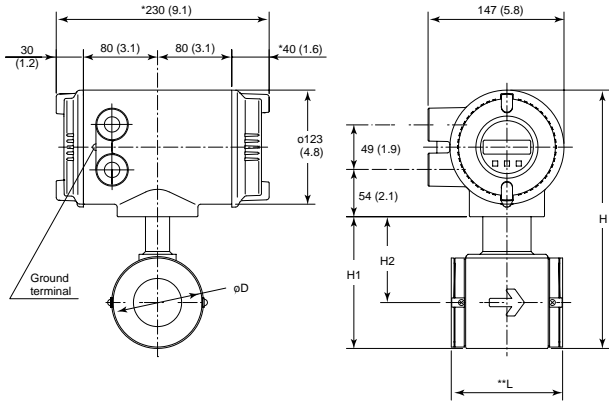

202
204
205 MG A^K
AE 206 MN-U^B
208 SC C^E
210 H

Unit: mm
(approx. inch)

Lining code A : PFA lining U : Polyurethane rubber lining C : Ceramic pipe

Type	General (MG)								Ex-proof (MN/SC)							
Size code	202	204	205	206	208	210	208	210	202	204	205	208	210	208	210	
Size	25 (1)	40 (1.5)	50 (2)	65 (2.5)	80 (3)	100 (4)	80 (3)	100 (4)	25 (1)	40 (1.5)	50 (2)	80 (3)	100 (4)	80 (3)	100 (4)	
Lining	A, U, C				A		A, U		C		A, C		A		C	
Face-to-face length	**L	93 (3.7)	106 (4.2)	120 (4.7)	120 (4.7)	160 (6.3)	180 (7.1)	160 (6.3)	180 (7.1)	93 (3.7)	106 (4.2)	120 (4.7)	160 (6.3)	180 (7.1)	160 (6.3)	180 (7.1)
Outer diameter	D	68 (2.7)	86 (3.4)	93 (3.9)	117 (4.6)	129 (5.1)	155 (6.1)	129 (5.1)	155 (6.1)	68 (2.7)	86 (3.4)	93 (3.9)	129 (5.1)	155 (6.1)	129 (5.1)	155 (6.1)
Height	H	251 (9.9)	271 (10.7)	284 (11.2)	302 (11.9)	324 (12.7)	350 (13.8)	314 (12.3)	350 (13.8)	249 (9.8)	269 (10.6)	282 (11.1)	322 (12.7)	348 (13.7)	312 (12.3)	348 (13.7)
Height	H1	111 (4.4)	131 (5.2)	144 (5.6)	162 (6.4)	184 (7.2)	210 (8.2)	174 (6.8)	210 (8.2)	109 (4.3)	129 (5.1)	142 (5.6)	182 (7.1)	208 (8.2)	172 (6.8)	208 (8.2)
Height	H2	77 (3.0)	88 (3.4)	94 (3.7)	104 (4.1)	119 (4.7)	132 (5.2)	109 (4.3)	132 (5.2)	75 (3.0)	86 (3.4)	92 (3.6)	117 (4.6)	130 (5.1)	107 (4.2)	130 (5.1)
Weight kg (lb)		4.6 (10.1)	5.5 (12.1)	6.5 (14.3)	7.5 (16.5)	9.6 (21.2)	12.5 (27.6)	9.2 (20.3)	12.3 (27.1)	4.6 (10.1)	5.5 (12.1)	6.5 (14.3)	9.6 (21.2)	12.5 (27.6)	9.2 (20.3)	12.3 (27.1)

- * The length marked as * is shorter by approx. 10mm(0.4 in.) for non indicator type.
- ** The face-to-face length is longer by approx. 22mm(0.87 in.) for earth ring P, T.
- ** The face-to-face length is longer by approx. 6mm(0.24 in.) for non earth ring type.
- ** The face-to-face length is longer by approx. 2mm(0.08 in.) for PFA lining with optional code/FRG.

F06.EPS

125 to 200mm(5 to 8in.) Wafer Type

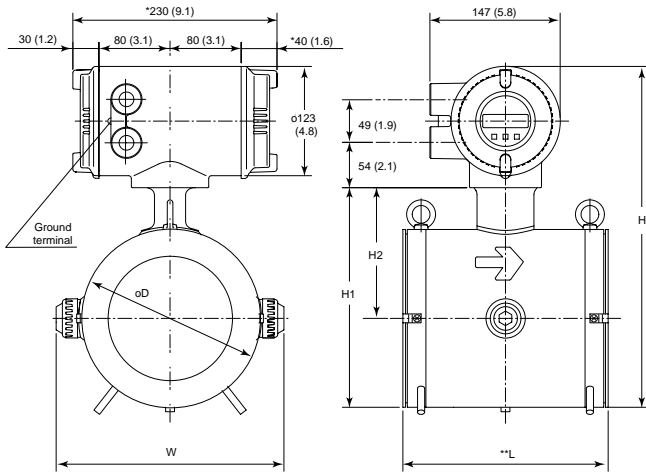

212 MG K
AE 215 MN-AB
220 SC UE
H

Unit: mm
(approx. inch)

Type	General (MG)			Ex-proof (MN/SC)		
Size code	212	215	220	215	220	
Size	125 (5)	150 (6)	200 (8)	150 (6)	200 (8)	
Lining	A		A, U			
Face-to-face length	**L	230 (9.1)	230 (9.1)	300 (11.8)	230 (9.1)	300 (11.8)
Outer diameter	D	175 (6.9)	200 (7.9)	250 (9.8)	200 (7.9)	250 (9.8)
Height	H	367(14.4)	392 (15.4)	442 (17.4)	390 (15.4)	440 (17.3)
Height	H1	227 (8.9)	252 (9.9)	302 (11.9)	250 (9.8)	300 (11.8)
Height	H2	140 (5.5)	152 (6.0)	177 (7.0)	150 (5.9)	175 (6.9)
Width	W	230 (9.1)	256 (10.1)	307 (12.1)	256 (10.1)	307 (12.1)
Weight kg (lb)		18 (39.7)	20.2 (44.5)	30.7 (67.6)	23.2 (51.1)	35.7 (68.6)

Lining code A : PFA lining
U : Polyurethane rubber lining

- * The length marked as * is shorter by approx. 10mm(0.4 in.) for non indicator type.
- ** The face-to-face length is shorter by approx. 6mm(0.24 in.) for non earth ring type.
- ** The face-to-face length is longer by approx. 30mm(1.18 in.) for earth ring P, T.
- ** The face-to-face length is longer by approx. 2mm(0.08 in.) for optional code/FRG.

F07.EPS

150 and 200mm(6 and 8in.) Ceramic Lining

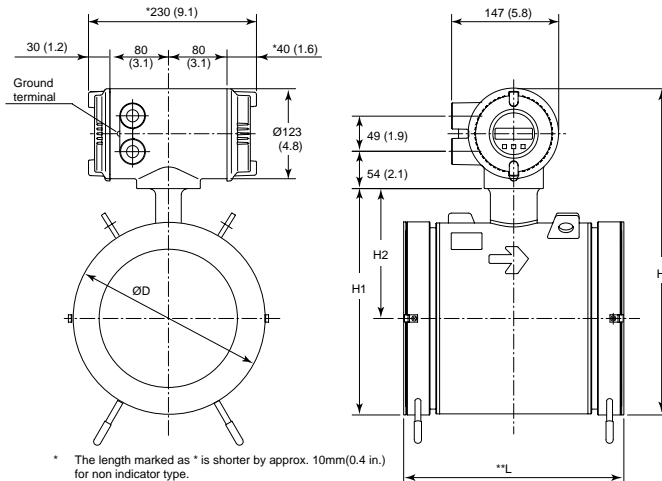

215 MG K
AE 220 MN-C^E
SC H

Unit: mm
(approx. inch)

Type	General (MG)		Ex-proof (MN/SC)		
Size code	215	220	215	220	
Size	150 (6.0)	200 (8.0)	150 (6.0)	200 (8.0)	
Lining	C (Ceramic)				
Face-to-face length	**L	232 (9.2)	302 (11.9)	232 (9.2)	302 (11.9)
Outer diameter	D	214 (8.4)	264 (10.4)	214 (8.4)	264 (10.4)
Height	H	406 (16.0)	456 (18.0)	404 (15.9)	454 (17.9)
Height	H1	266 (10.5)	316 (12.4)	264 (10.4)	314 (12.4)
Height	H2	159 (6.3)	184 (7.2)	157 (6.2)	182 (7.2)
Weight kg (lb)		23.9 (52.6)	35.9 (79.1)	26.9 (59.3)	40.9 (90.1)

- * The length marked as * is shorter by approx. 10mm(0.4 in.) for non indicator type.
- ** The face-to-face length is shorter by approx. 6mm(0.24 in.) for non earth ring type.

F08.EPS

250 to 300mm(10 to 12in.) Wafer Type

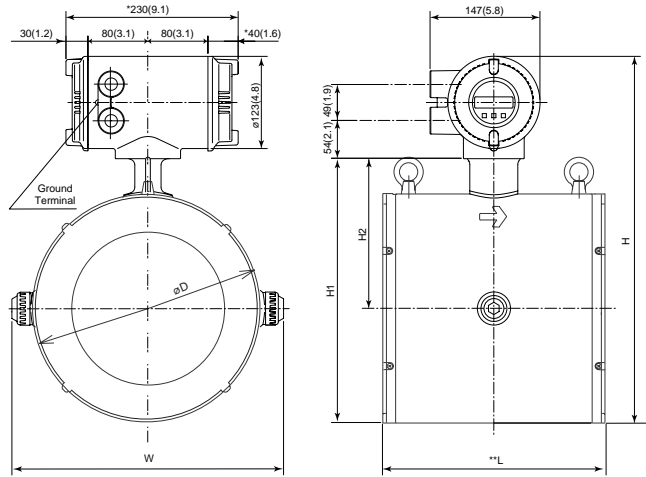

		K AE 325 MG-AB 300 UE H	
Type	General (MG)		
Size code	325	300	
Size	250 (10)	300 (12)	
Lining	A, U		
Face-to-face length	**L	300 (11.8)	350 (13.8)
Outer diameter	D	310 (12.2)	358 (14.1)
Height	H	502 (19.8)	550 (21.7)
Height	H1	362 (14.3)	410 (16.1)
Height	H2	207 (8.1)	231 (9.1)
Width	W	366 (14.4)	415 (16.3)
Weight kg (lb)		35.3 (77.8)	44.6(98.3)

Lining code A : PFA lining
 U : Polyurethane rubber lining
 * The length marked as * is shorter by approx. 10mm(0.4 in.) for non indicator type.
 ** The face-to-face length is shorter by approx. 2mm(0.08 in.) for non earth ring type.

15mm(0.5in.) Flange Type

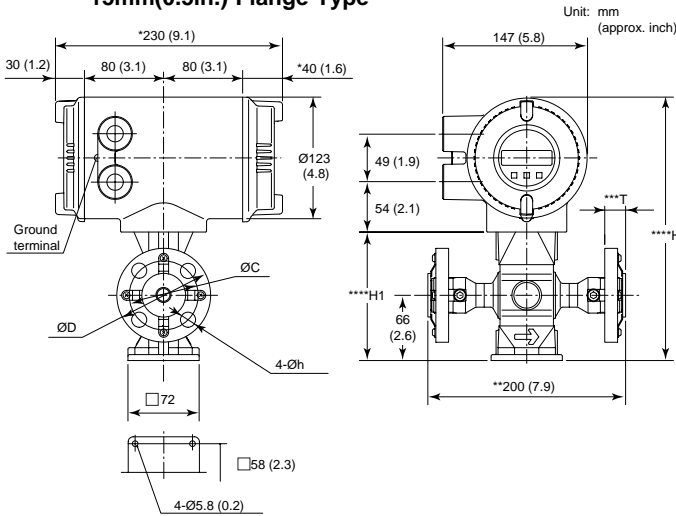

- * The length marked as * is shorter by approx. 10mm(0.4 in.) for non indicator type.
- ** The face-to-face length is longer by approx. 22mm(0.87 in.) for earth ring P, T.
- *** The thickness (T) is longer by approx. 11mm(0.43 in.) for earth ring P, T.
- **** The face-to-face length is shorter by approx. 6mm(0.24 in.) for non earth ring type.
- ***** The thickness (T) is shorter by approx. 3mm(0.12 in.) for non earth ring type.
- ***** The face-to-face length is longer by approx. 2mm(0.08 in.) for optional code/FRG.
- ***** The thickness (T) is longer by approx. 1mm(0.04 in.) for optional code/FRG.
- ***** The height is shorter by approx. 2.5mm(0.1 in.) for ex-proof type.

F09-1.EPS

25 to 50mm(1 to 2in.) Flange Type

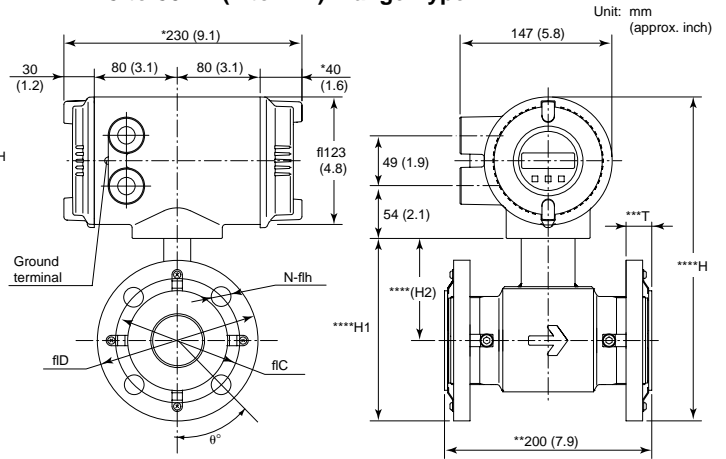

- * The length marked as * is shorter by approx. 10mm(0.4 in.) for non indicator type.
- ** The face-to-face length is longer by approx. 22mm(0.87 in.) for earth ring P, T.
- *** The thickness (T) is longer by approx. 11mm(0.43 in.) for earth ring P, T.
- **** The face-to-face length is shorter by approx. 6mm(0.24 in.) for non earth ring type.
- ***** The thickness (T) is shorter by approx. 3mm(0.12 in.) for non earth ring type.
- ***** The face-to-face length is longer by approx. 2mm(0.08 in.) for optional code / FRG.
- ***** The thickness (T) is longer by approx. 1mm(0.04 in.) for optional code /FRG.
- ***** The height is shorter by approx. 2mm(0.08 in.) for ex-proof type.

F10-1.EPS

MG J
AE115MN-AA
SC D

Type	General (MG), Ex-proof (MN/SC)					
Size code	115					
Size	15 (0.5)					
Lining	A (PFA)					
Process connection	J1	J2	A1	A2	D2	D4
Height	****H 267.5 (10.5)					
Height	****H1 127.5 (5.0)					
Outer diameter	D	95 (3.7)	95 (3.7)	88.9 (3.5)	95.3 (3.8)	95 (3.7)
Thickness	***T	19 to 24 (0.7 to 0.9)	21 to 26 (0.8 to 1.0)	18 to 25 (0.7 to 1.0)	21 to 28 (0.8 to 1.1)	20 to 26 (0.8 to 1.0)
Pitch circle dia.	C	70 (2.8)	70 (2.8)	60.5 (2.4)	66.5 (2.6)	65 (2.6)
Dia. of hole	h	15 (0.6)	15 (0.6)	15.7 (0.6)	15.7 (0.6)	14 (0.6)
Weight kg (lb)		6.3 (13.9)	6.5 (14.3)	6.1 (13.4)	6.5 (14.3)	6.5 (14.3)

Process connection : J1;JIS10K J2;JIS20K A1;ANSI 150 A2;ANSI 300 D2;DIN PN16
 D4;DIN PN40 F09-02.EPS

202 MG A J
AE 204 MN- A J
205 SC U D

Size code	202						204						205					
Size	25(1.0)						40(1.5)						50(2.0)					
Lining	A(PFA), U(Polyurethane)						A(PFA), U(Polyurethane)						A(PFA), U(Polyurethane)					
Process connection	J1	J2	A1	A2	D2	D4	J1	J2	A1	A2	D2	D4	J1	J2	A1	A2	D2	D4
Height	****H 279.3 (11.0)						****H 304.7 (11.9)						****H 311.5 (12.3)					
Height	****H1 139.3 (5.5)						****H1 157 (6.2)						****H1 171.5 (6.8)					
Height	****H2 76.8(3.0)						****H2 87(3.4)						****H2 94(3.7)					
Outer diameter	D	125 (4.9)	125 (4.9)	108 (4.3)	124 (4.9)	115 (4.5)	140 (5.5)	140 (5.5)	127 (5.0)	155.4 (6.1)	150 (5.9)	150 (5.9)	155 (6.1)	155 (6.1)	152.4 (6.0)	165.1 (6.5)	165 (6.5)	165 (6.5)
Thickness	***T	21(0.8) to 26(1.1)	23(0.9) to 28(1.1)	21(0.8) to 26(1.1)	22(0.9) to 28(1.1)	24(0.9) to 30(1.2)	23(0.9) to 28(1.1)	25(1.0) to 30(1.2)	25(1.0) to 31(1.2)	28(1.1) to 34(1.3)	22(0.9) to 28(1.1)	30(1.2) to 36(1.4)	23(0.9) to 29(1.1)	25(1.0) to 31(1.2)	26(1.0) to 32(1.3)	30(1.2) to 36(1.4)	24(0.9) to 30(1.2)	26(1.0) to 32(1.3)
Pitch circle dia.	C	90 (3.5)	90 (3.5)	79.2 (3.1)	88.9 (3.5)	85 (3.3)	105 (4.1)	105 (4.1)	98.6 (3.9)	114.3 (4.5)	110 (4.3)	110 (4.3)	120 (4.7)	120 (4.7)	120.7 (4.8)	127 (5.0)	125 (4.9)	125 (4.9)
Dia. of hole	h	19 (0.7)	19 (0.7)	15.7 (0.6)	19.1 (0.8)	14 (0.6)	19 (0.7)	19 (0.7)	15.7 (0.6)	22.4 (0.9)	18 (0.7)	18 (0.7)	19 (0.7)	19 (0.7)	19.1 (0.8)	19.1 (0.8)	18 (0.7)	18 (0.7)
Number of holes	N	4	4	4	4	4	4	4	4	4	4	4	4	4	8	4	8	4
Weight kg (lb)		7.5 (16.5)	7.8 (17.2)	6.9 (15.2)	7.5 (17.4)	7.4 (16.3)	9.7 (21.4)	10.0 (22.0)	8.3 (18.3)	11.5 (25.3)	10.3 (22.7)	10.3 (22.7)	11.3 (24.9)	11.4 (25.1)	11.7 (25.8)	13.1 (28.9)	12.5 (27.5)	12.5 (27.5)

Process Connection: J1;JIS10K J2;JIS20K A1;ANSI 150 A2;ANSI 300 D2;DIN PN16 D4;DIN PN40

F10-2.EPS

80 and 100mm(3 and 4in.) Flange Type

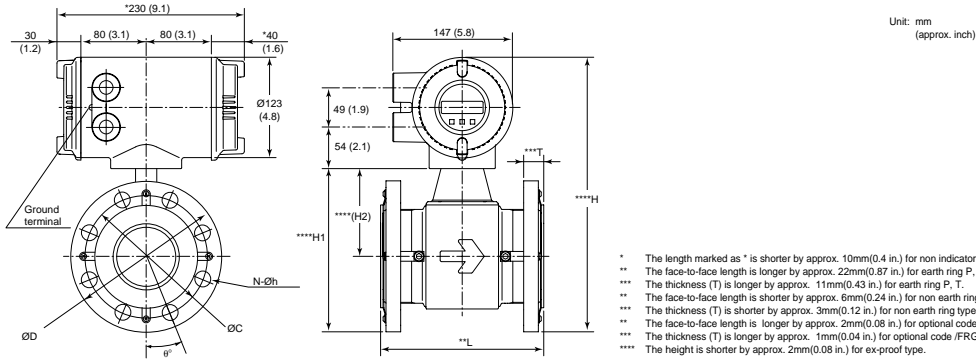

Unit: mm (approx. inch)

- * The length marked as * is shorter by approx. 10mm(0.4 in.) for non indicator type.
- ** The face-to-face length is longer by approx. 22mm(0.87 in.) for earth ring P, T.
- *** The thickness (T) is longer by approx. 11mm(0.43 in.) for earth ring P, T.
- **** The face-to-face length is shorter by approx. 6mm(0.24 in.) for non earth ring type.
- ***** The thickness (T) is shorter by approx. 3mm(0.12 in.) for non earth ring type.
- ***** The face-to-face length is longer by approx. 2mm(0.08 in.) for optional code /FRG.
- ***** The thickness (T) is longer by approx. 1mm(0.04 in.) for optional code /FRG.
- ***** The height is shorter by approx. 2mm(0.08 in.) for ex-proof type.

J
AA
UD
G
AE 208 MG MN SC

Size code	208						210						
	80(3.0)						100(4.0)						
Lining	A(PFA, U(Polyurethane))						A(PFA, U(Polyurethane))						
Process connection	J1	J2	A1	A2	D2	G1	J1	J2	A1	A2	D2	G1	
Height	****H	341.5 (13.4)	349 (13.7)	344.3 (13.5)	353.8 (13.9)	349 (13.7)	354.5 (14.0)	377 (14.8)	384.5 (15.1)	386.3 (15.2)	399 (15.7)	382 (15.0)	391 (15.4)
Height	****H1	201.5 (7.9)	209 (8.2)	204.3 (8.0)	213.8 (8.4)	209 (8.2)	214.5 (8.4)	237 (9.3)	244.5 (9.6)	246.3 (9.7)	259 (10.2)	242 (9.5)	251 (9.9)
Height	****H2	109(4.3)						132(5.2)					
Outer diameter	D	185 (7.3)	200 (7.9)	190.5 (7.5)	209.6 (8.3)	200 (7.9)	211 (8.3)	210 (8.3)	225 (8.9)	228.6 (9.0)	254 (10.0)	220 (8.7)	238 (9.4)
Thickness	***T	25(1.0) to 31(1.2)	29(1.1) to 35(1.4)	31(1.2) to 38(1.5)	36(1.4) to 43(1.7)	26(1.0) to 32(1.3)	25(1.0) to 31(1.5)	31(1.2) to 37(1.5)	31(1.2) to 38(1.5)	39(1.5) to 46(1.8)	26(1.0) to 32(1.3)	25(1.0) to 32(1.3)	25(1.0) to 32(1.3)
Pitch circle dia.	C	150 (5.9)	160 (6.3)	152.4 (6.0)	168.1 (6.6)	160 (6.3)	168 (6.6)	175 (6.9)	185 (7.3)	190.5 (7.5)	200.2 (7.9)	180 (7.1)	195 (7.7)
Bolt hole pitch	e ^o	22.5	22.5	45	22.5	22.5	45	22.5	22.5	22.5	22.5	45	45
Dia. of hole	h	19 (0.7)	23 (0.9)	19.1 (0.7)	22.4 (0.9)	18 (0.7)	19 (0.7)	19 (0.7)	23 (0.9)	19.1 (0.7)	22.4 (0.9)	18 (0.7)	19 (0.7)
Number of holes	N	8	8	4	8	8	4	8	8	8	8	8	4
Face-to-face length	**L	200(7.9)						250(9.8)					
Weight kg (lb)		15.3 (33.7)	17.3 (38.1)	17.6 (38.8)	20.6 (45.4)	17.3 (38.1)	17.8 (39.2)	23.3 (51.3)	26.5 (58.4)	27.3 (60.1)	34.7 (76.4)	25.0 (55.1)	26.4 (58.1)

F11.EPS

Process Connection : J1; JIS10K J2; JIS20K A1; ANSI 150 A2; ANSI 300 D2; DIN PN16 G1; JIS F12

150 and 200mm(6 and 8in.) Flange Type

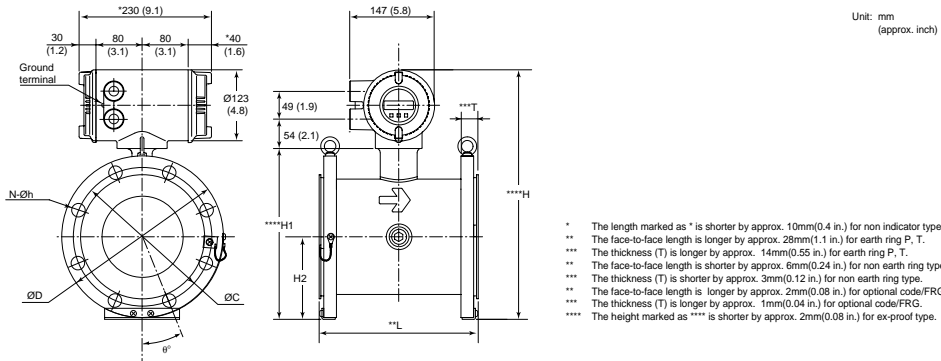

Unit: mm (approx. inch)

- * The length marked as * is shorter by approx. 10mm(0.4 in.) for non indicator type.
- ** The face-to-face length is longer by approx. 28mm(1.1 in.) for earth ring P, T.
- *** The thickness (T) is longer by approx. 14mm(0.55 in.) for earth ring P, T.
- **** The face-to-face length is shorter by approx. 6mm(0.24 in.) for non earth ring type.
- ***** The thickness (T) is shorter by approx. 3mm(0.12 in.) for non earth ring type.
- ***** The face-to-face length is longer by approx. 2mm(0.08 in.) for optional code /FRG.
- ***** The thickness (T) is longer by approx. 1mm(0.04 in.) for optional code /FRG.
- ***** The height marked as **** is shorter by approx. 2mm(0.08 in.) for ex-proof type.

J
AA
UD
G
AE 215 MG MN SC

Size code	215						220							
	150 (6.0)						200 (8.0)							
Lining	A (PFA, U (Polyurethane))						A (PFA, U (Polyurethane))							
Process connection	J1	G1	A1	J2	A2	D2	J1	G1	A1	J2	A2	D1	D2	
Face-to-face length	270 (10.6)						340 (13.4)							
Outer diameter	D	290 (11.0)	290 (11.4)	290 (11.0)	305 (12.0)	320 (12.6)	285 (11.2)	330 (13.0)	342 (13.5)	345 (13.6)	350 (13.8)	380 (15.0)	340 (13.4)	340 (13.4)
Height	****H	435 (17.1)	440.5 (17.3)	245.5 (9.7)	448.5 (17.7)	455.5 (17.9)	438.5 (17.3)	485 (19.1)	491.5 (19.4)	491.5 (19.4)	495.5 (19.5)	508.5 (20.0)	488.5 (19.2)	488.5 (19.2)
Height	****H1	295 (11.6)	300.5 (11.8)	295.5 (11.6)	308.5 (12.1)	315.5 (12.4)	298.5 (11.8)	345 (13.6)	351.5 (13.8)	351.5 (13.8)	355.5 (14.0)	368.5 (14.5)	348.5 (13.7)	348.5 (13.7)
Height	H2	143 (5.6)	148 (5.8)	143 (5.6)	156 (6.1)	163 (6.4)	146 (5.7)	168 (6.6)	174 (6.9)	176 (6.9)	178 (7.0)	193 (7.6)	173 (6.8)	173 (6.8)
Pitch circle dia.	C	240 (9.4)	247 (9.7)	241 (9.5)	260 (10.2)	270 (10.6)	240 (9.4)	290 (11.4)	299 (11.8)	298 (11.7)	305 (12.0)	330 (13.0)	295 (11.6)	295 (11.6)
Bolt hole pitch	e ^o	22.5	30	22.5	15	15	22.5	15	22.5	22.5	15	15	22.5	15
Number of holes	N	8	6	8	12	12	8	12	8	8	12	12	8	12
Dia. of hole	h	23 (0.9)	19 (0.7)	23 (0.9)	25 (1.0)	22 (0.9)	22 (0.9)	23 (0.9)	19 (0.7)	23 (0.9)	25 (1.0)	25 (1.0)	22 (0.9)	22 (0.9)
Thickness (PFA)	***T	30 (1.2)	30 (1.2)	33.4 (1.3)	36 (1.4)	44.5 (1.8)	30 (1.2)	30 (1.2)	36.4 (1.4)	38 (1.5)	49.1 (1.9)	32 (1.3)	32 (1.2)	
Thickness (Polyurethane)	***T	31 (1.2)	31 (1.2)	34.4 (1.4)	37 (1.5)	45.5 (1.8)	31 (1.2)	31 (1.2)	33 (1.3)	37.4 (1.5)	39 (1.5)	50.1 (2.0)	33 (1.3)	
Weight kg (lb)		31.3 (68.9)	33.3 (73.3)	33.3 (73.3)	39.3 (86.6)	50.3 (110.8)	33.3 (73.3)	43.3 (95.4)	48.3 (106.4)	51.3 (113.0)	54.3 (120.0)	75.3 (165.9)	47.3 (104.2)	48.3 (106.4)
Weight kg (lb)		34.3 (75.6)	36.3 (80.0)	36.3 (80.0)	42.3 (93.2)	53.3 (117.4)	36.3 (80.0)	48.3 (106.4)	53.3 (117.4)	56.3 (124.0)	59.3 (130.6)	80.3 (176.9)	52.3 (115.2)	53.3 (117.4)

Process connection : J1; JIS10K J2; JIS20K A1; ANSI 150 A2; ANSI 300 D1; DIN PN10 D2; DIN PN16 G1; JIS F12

F12.EPS

AE325MG/N-J/G/A/D, AE330MG/N-J/G/A/D, AE335MG/N-J/G/A/D, AE340MG/N-J/G/A/D Integral Type Magnetic Flowmeter (Flange Type)

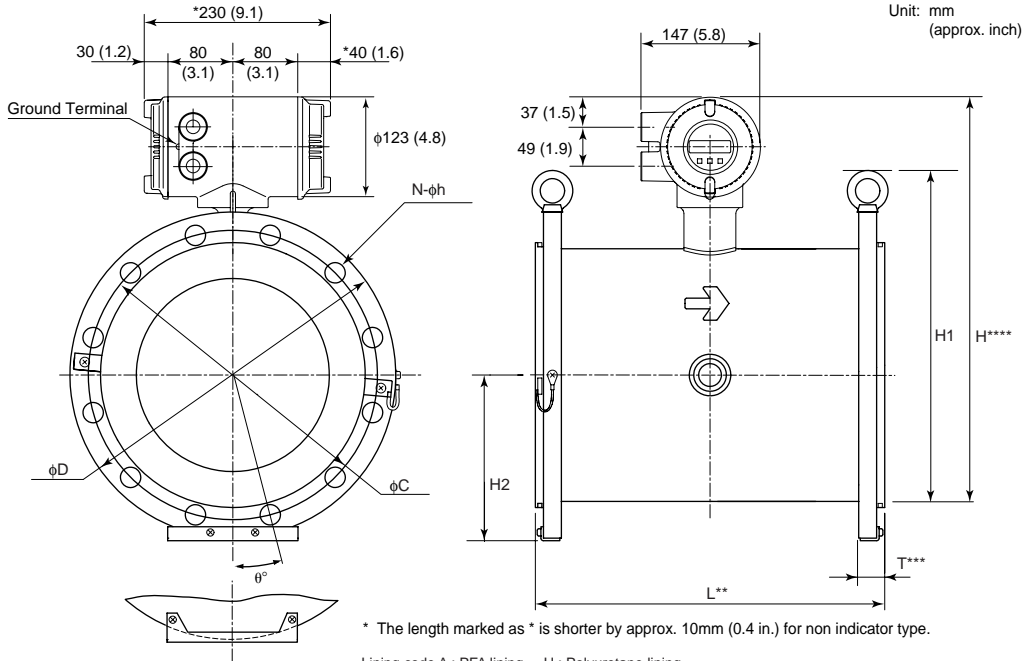

for AE330, AE335, AE340

- * The length marked as * is shorter by approx. 10mm (0.4 in.) for non indicator type.
- Lining code A : PFA lining U : Polyurethane lining
- ** The face-to-face length is shorter by approx. 6mm(0.24 in.) for non earth ring type of AE325 and AE330, by approx. 10mm(0.39 in.) for non earth ring type of AE335 and AE340.
- *** The thickness(T) is shorter by approx. 3mm(0.12 in.) for non earth ring type of AE325 and AE330, by approx. 5mm(0.20 in.) for non earth ring type of AE335 and AE340.
- **** The height(H) is shorter by approx. 2mm(0.08 in.) for ex-proof type.

Type	General(G), Ex-proof(N)			
	325	330	335	340
Size code	325	330	335	340
Size	250	300	350	400
Lining code	A(PFA) U(Polyurethane)			
Face-to-face L**	430(16.9)	500(19.7)	550(21.7)	600(23.6)
Eye bolt hole dia. e	30(1.2)	30(1.2)	35(1.4)	35(1.4)
Height	H****	550(21.7)	597(23.5)	640(25.2)
	H1	454(17.9)	499(19.7)	553(21.8)
Outer dia. φD	H2	203(7.9)	226(9.0)	248(9.8)
	φC	400(15.8)	445(17.5)	490(19.3)
Pitch circle dia. φC	φD	355(14.0)	400(15.8)	445(17.5)
	φC	355(14.0)	400(15.8)	445(17.5)
Number of holes N	φC	355(14.0)	400(15.8)	445(17.5)
	φC	355(14.0)	400(15.8)	445(17.5)
Bolt hole pitch θ°	N	12	16	16
	θ°	15	11.25	11.25
Hole dia. φh	θ°	15	11.25	11.25
	φh	25(1.0)	25(1.0)	25(1.0)
Thickness(A) T***	φh	25(1.0)	25(1.0)	27(1.1)
	T***	32(1.3)	34(1.3)	36(1.4)
Thickness(U) T****	T***	33(1.3)	35(1.4)	37(1.4)
	T****	33(1.3)	35(1.4)	39(1.5)
Weight (General) kg(lb)	Weight (General) kg(lb)	66.3(146.2)	83.3(183.6)	96.3(212.3)
	Weight (Ex-proof) kg(lb)	70.3(155.0)	87.3(192.5)	102.3(225.5)

Type	General(G), Ex-proof(N)			
	325	330	335	340
Size code	325	330	335	340
Size	250	300	350	400
Lining code	A(PFA) U(Polyurethane)			
Face-to-face L**	430(16.9)	500(19.7)	550(21.7)	600(23.6)
Eye bolt hole dia. e	30(1.2)	30(1.2)	35(1.4)	35(1.4)
Height	H****	553(21.8)	616(24.3)	662(26.1)
	H1	461(18.1)	537(21.1)	597(23.5)
Outer dia. φD	H2	206(8.1)	245(9.7)	270(10.6)
	φD	406(16.0)	483(19.0)	533(21.0)
Pitch circle dia. φC	φD	406(16.0)	483(19.0)	533(21.0)
	φC	362(14.3)	432(17.0)	476(18.7)
Number of holes N	φC	362(14.3)	432(17.0)	476(18.7)
	φC	362(14.3)	432(17.0)	476(18.7)
Bolt hole pitch θ°	N	12	12	12
	θ°	15	15	15
Hole dia. φh	θ°	15	15	15
	φh	26(1.0)	26(1.0)	29(1.1)
Thickness(A) T***	φh	26(1.0)	26(1.0)	29(1.1)
	T***	38(1.5)	40(1.6)	45(1.8)
Thickness(U) T****	T***	39(1.5)	41(1.6)	46(1.8)
	T****	39(1.5)	41(1.6)	48(1.9)
Weight (General) kg(lb)	Weight (General) kg(lb)	72.3(159.4)	92.3(203.5)	112.3(247.6)
	Weight (Ex-proof) kg(lb)	76.3(168.2)	96.3(212.3)	118.3(260.8)

F13.EPS

Magnetic Flow Tube

2.5 to 15mm(0.1 to 0.5in.) Wafer Type

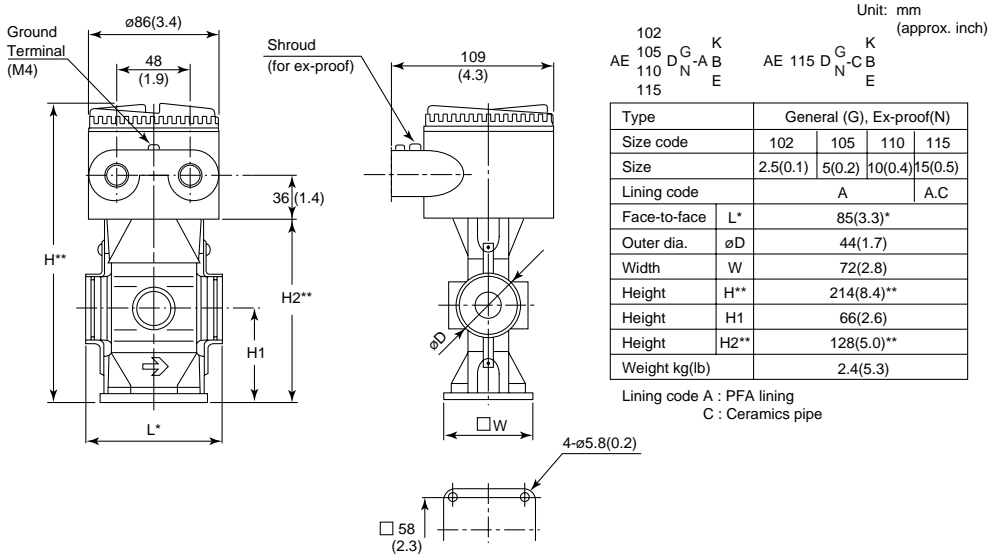

Unit: mm (approx. inch)
 102 AE 105 D^G N^K-A B E
 110 AE 115 D^G N^K-C B E
 115

Type	General (G), Ex-proof(N)			
Size code	102	105	110	115
Size	2.5(0.1)	5(0.2)	10(0.4)	15(0.5)
Lining code	A		A.C	
Face-to-face	L*	85(3.3)*		
Outer dia.	øD	44(1.7)		
Width	W	72(2.8)		
Height	H**	214(8.4)**		
Height	H1	66(2.6)		
Height	H2**	128(5.0)**		
Weight kg(lb)	2.4(5.3)			

Lining code A : PFA lining
 C : Ceramics pipe

- * The face-to-face length is longer by approx.22mm(0.89 in.) for earth ring P.T.
- * The face-to-face length is shorter by approx. 6mm(0.24 in.) for non earth ring type.
- * The face-to-face length is longer by approx.2mm(0.08 in.) for PFA lining with optional code/FRG.
- ** The height marked as ** is shorter by 3mm(0.12 in.) for ex-proof type.

F15.EPS

2.5 to 10mm(0.1 to 0.4in.) Union Joint Type

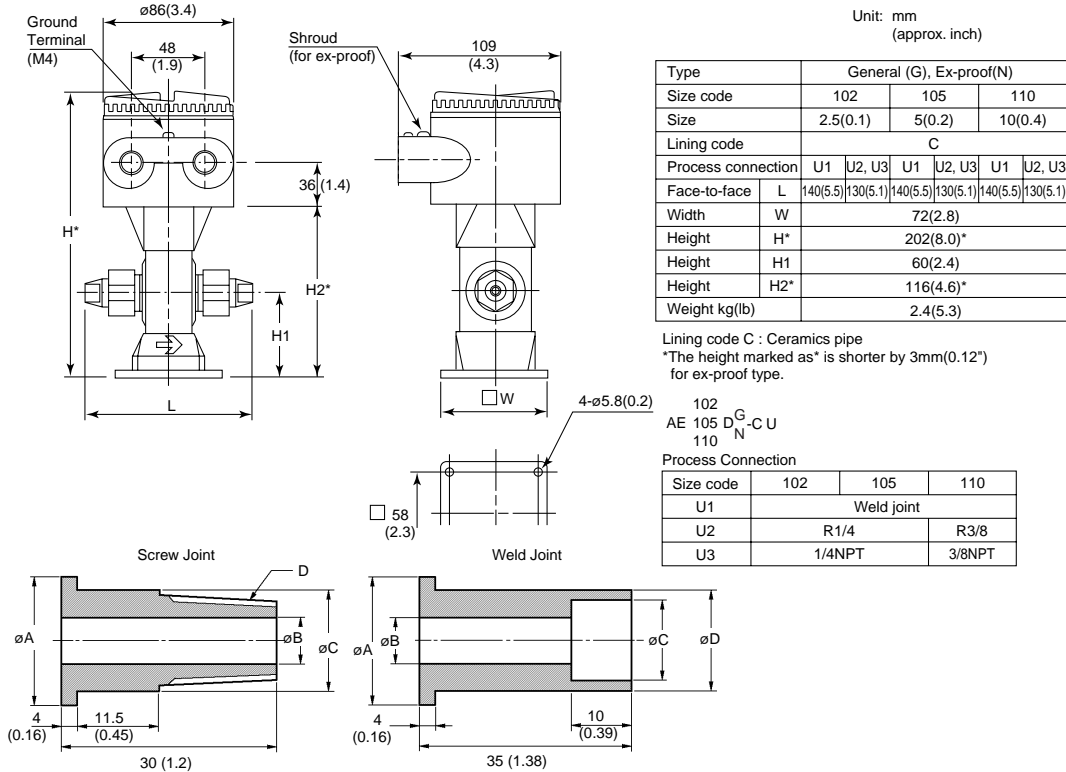

Unit: mm (approx. inch)

Type	General (G), Ex-proof(N)					
Size code	102		105		110	
Size	2.5(0.1)		5(0.2)		10(0.4)	
Lining code	C					
Process connection	U1	U2, U3	U1	U2, U3	U1	U2, U3
Face-to-face	L	140(5.5)	130(5.1)	140(5.5)	130(5.1)	140(5.5)
Width	W	72(2.8)				
Height	H*	202(8.0)*				
Height	H1	60(2.4)				
Height	H2*	116(4.6)*				
Weight kg(lb)	2.4(5.3)					

Lining code C : Ceramics pipe
 *The height marked as * is shorter by 3mm(0.12") for ex-proof type.

102 AE 105 D^G N^K-C U
 110

Process Connection

Size code	102	105	110
U1	Weld joint		
U2	R1/4	R3/8	
U3	1/4NPT	3/8NPT	

Size	A	B	C	D
2.5	22(0.87)	8(0.31)	18.5(0.73)	R1/4
0.1	22(0.87)	8(0.31)	18.5(0.73)	NPT1/4
5	22(0.87)	8(0.31)	18.5(0.73)	R1/4
0.2	22(0.87)	8(0.31)	18.5(0.73)	NPT1/4
10	25(0.98)	10(0.39)	22.5(0.89)	R3/8
0.4	25(0.98)	10(0.39)	22.5(0.89)	NPT3/8

Size	A	B	C	D
2.5(0.1)	22(0.87)	8(0.31)	14.3(0.56)	18.5(0.73)
5(0.2)	22(0.87)	8(0.31)	14.3(0.56)	18.5(0.73)
10(0.4)	25(0.98)	10(0.39)	17.8(0.70)	22.5(0.89)

F16.EPS

25 to 100mm(1 to 4in.) Wafer Type

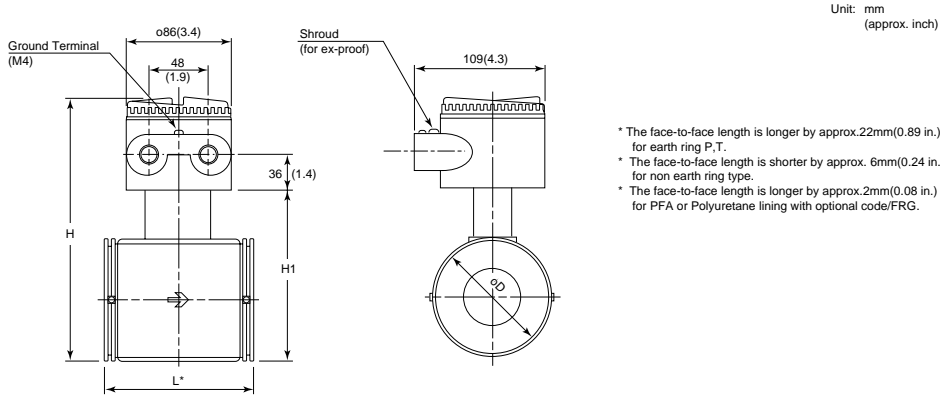

Unit: mm
(approx. inch)

- * The face-to-face length is longer by approx.22mm(0.89 in.) for earth ring P.T.
- * The face-to-face length is shorter by approx. 6mm(0.24 in.) for non earth ring type.
- * The face-to-face length is longer by approx.2mm(0.08 in.) for PFA or Polyurethane lining with optional code/FRG.

202
204
205
AE 206
208
210

K
G - AB
D N - UE
CH

Type	General(G)								EX-proof(N)							
	202	204	205	206	208	210	208	210	202	204	205	208	210	208	210	
Size code	202	204	205	206	208	210	208	210	202	204	205	208	210	208	210	
Size	25(1)	40(1.5)	50(2)	65(2.5)	80(3)	100(4)	80(3)	100(4)	25(1)	40(1.5)	50(2)	80(3)	100(4)	80(3)	100(4)	
Lining code	A,U,C				A				A,C				A			
Face-to-face	L*	93(3.7)*	106(4.2)*	120(4.7)*	120(4.7)	160(6.3)*	180(7.1)*	160(6.3)*	180(7.1)*	93(3.7)*	106(4.2)*	120(4.7)*	160(6.3)*	180(7.1)*	160(6.3)*	180(7.1)*
Outer dia	D	68(2.7)	86(3.4)	99(3.9)	117(4.6)	129(5.1)	155(6.1)	129(5.1)	155(6.1)	68(2.7)	86(3.4)	99(3.9)	129(5.1)	155(6.1)	129(5.1)	155(6.1)
Height	H	197(7.8)	217(8.5)	230(9.1)	248(9.8)	270(10.6)	296(11.7)	260(10.2)	296(11.7)	195(7.7)	214(8.4)	228(9.0)	268(10.6)	296(11.7)	258(10.2)	294(11.6)
Height	H1	111(4.4)	131(5.2)	144(5.7)	162(6.4)	184(7.2)	210(8.3)	174(6.9)	210(8.3)	109(4.3)	128(5.0)	142(5.6)	182(7.2)	208(8.2)	172(6.8)	208(8.2)
Weight kg(lb)		2.3(5.5)	3.2(7.1)	4.2(9.3)	5.2(11.5)	7.3(16.1)	10.2(22.5)	6.9(15.2)	10(22.1)	2.3(5.5)	3.2(7.1)	4.2(9.3)	7.3(16.1)	10.2(22.5)	6.9(15.2)	10(22.1)

Lining code A : PFA lining
U : Polyurethane rubber lining
C : Ceramics pipe

F17.EPS

125 to 200mm(5 to 8in.) Wafer Type

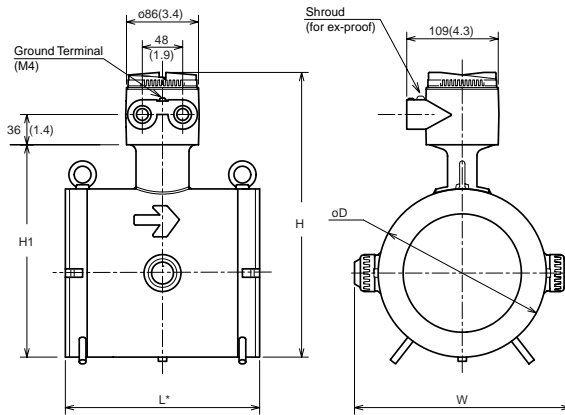

Unit: mm
(approx. inch)

AE 212
215
220
D N - UE
H

Type	General(G)			Ex-proof(N)		
	212	215	220	215	220	220
Size code	212	215	220	215	220	220
Size	125(5)	150(6)	200(8)	150(6)	200(8)	200(8)
Lining code	A			A, U		
Face-to-face	L*	230(9.1)*	300(11.8)*	230(9.1)*	300(11.8)*	300(11.8)*
Outer dia.	D	175(6.9)	200(7.9)	250(9.8)	200(7.9)	250(9.8)
Height	H	313(12.3)	339(13.3)	389(15.3)	336(13.2)	386(15.2)
Height	H1	227(8.9)	253(10.0)	303(11.9)	250(10.1)	300(11.8)
Width	W	230(9.1)	256(10.1)	307(12.1)	256(10.1)	307(12.1)
Weight kg(lb)		15.7(34.6)	17.9(39.4)	28.4(62.6)	20.9(46.1)	33.4(73.6)

- Lining code A : PFA lining
U : Polyurethane rubber lining
- * The face-to-face length is longer by approx.30mm(1.2 in.) for earth ring P.T.
 - * The face-to-face length is shorter by approx. 6mm(0.24 in.) for non earth ring type.
 - * The face-to-face length is longer by approx.2mm(0.08 in.) for optional code/FRG.

F18.EPS

150 and 200mm(6 and 8in.) Ceramic Lining

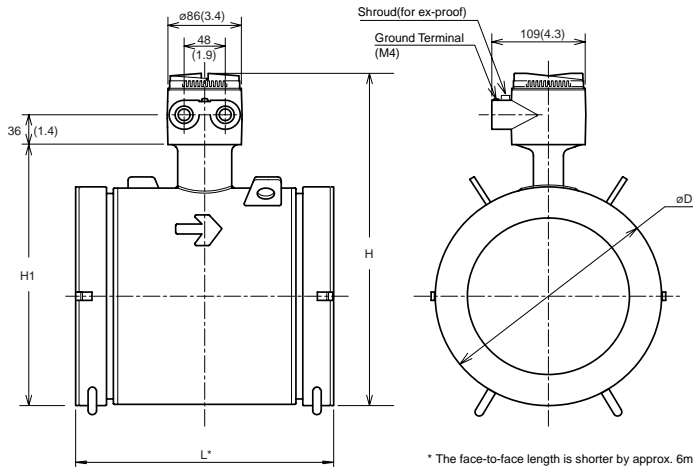

Unit: mm
(approx. inch)

AE 215
220
D N - C
H

Type	General(G)		Ex-proof(N)	
	215	220	215	220
Size code	215	220	215	220
Size	150(6)	200(8)	150(6)	200(8)
Lining code	C			
Face-to-face	L*	232(9.2)*	302(11.9)*	302(11.9)*
Outer dia	øD	214(8.5)	264(10.4)	214(8.4)
Height	H	352.5(13.9)	402.5(15.8)	350(13.8)
Height	H1	266.5(10.5)	316.5(12.5)	264(10.4)
Weight kg(lb)		21.6(47.7)	33.6(74.1)	24.6(54.2)

Lining code C : Ceramics pipe

* The face-to-face length is shorter by approx. 6mm(0.24 in.) for non earth ring type.

F19.EPS

250 to 300mm(10 to 12in.) Wafer Type:

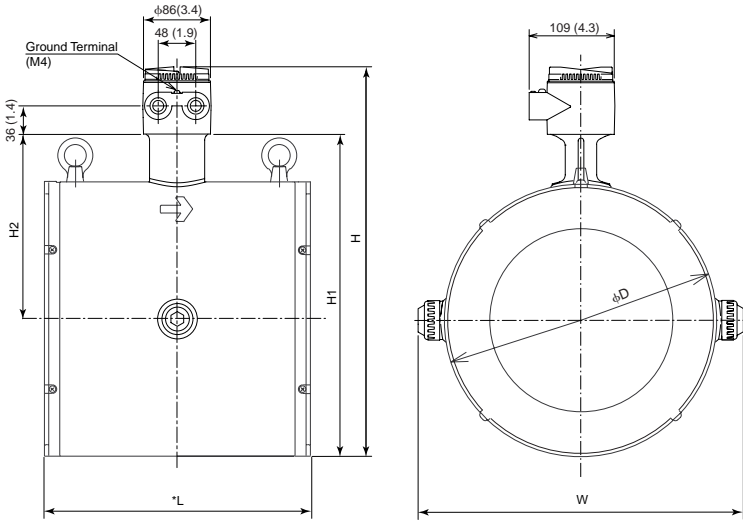

AE 325 DG - A B E H		K	
Type		General (G)	
Size code	325	330	
Size	250(10)	300(12)	
Lining code	A, U		
Face-to-face	*L	300(11.8)	350(13.8)
Outer dia.	D	310(12.2)	358(14.1)
Height	H	449(17.7)	497(19.6)
Height	H1	363(14.3)	411(16.2)
Height	H2	208(8.2)	232(9.1)
Width	W	366(14.4)	415(16.3)
Weight kg (lb)		33(72.8)	42.3(93.3)

Lining code A : PFA lining
 U : Polyurethane rubber lining
 * The face-to-face length is shorter by approx. 2mm(0.08 in.) for non earth ring type.
 SD4b.eps

15mm(0.5in.) Flange Type:

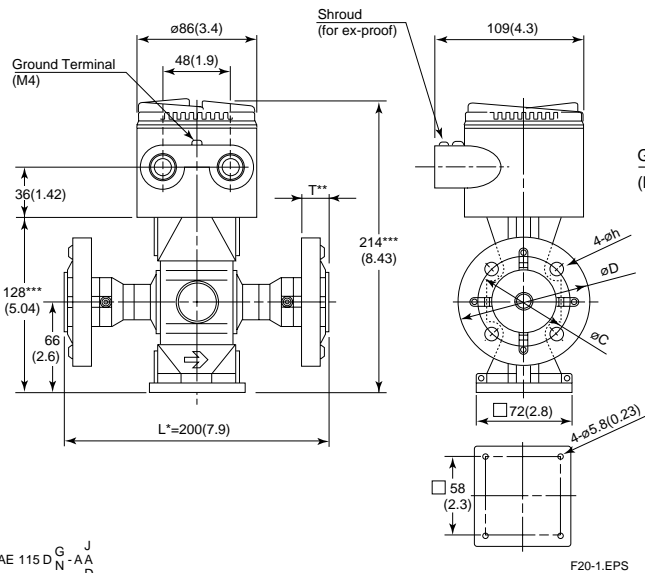

25 to 50mm(1 to 2in.) Flange Type:

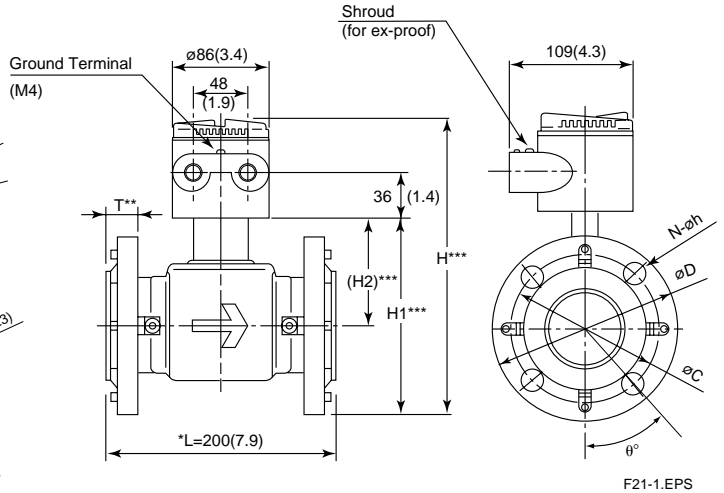

AE 115 D^G N^J - AA^A D

Type	General(G) Ex-proof(N)					
Size code	115					
Size	15(0.5)					
Lining code	A					
Process Connection	J1	J2	A1	A2	D2	D4
Outer dia.	øD	95(3.7)	95(3.7)	89(3.5)	95(3.7)	95(3.7)
Thickness	T**	19(0.7)to 24(0.9)**	21(0.8)to 26(1.0)**	18(0.7)to 25(1.0)**	21(0.8)to 28(1.1)**	20(0.8)to 26(1.0)**
Pitch circle dia.	øC	70(2.8)	70(2.8)	61(2.4)	67(2.6)	65(2.6)
Hole dia.	øh	15(0.6)	15(0.6)	16(0.6)	16(0.6)	14(0.6)
Weight kg(lb)		4.0(8.8)	4.2(9.3)	3.8(8.4)	4.2(9.3)	4.2(9.3)

Process connection : J1: JIS10K J2: JIS20K A: ANSI 150
 A2: ANSI 300 D2: DIN PN16 D4: DIN PN40
 Lining code A : PFA lining
 F20-2.EPS

202 AE 204 D^G N^J - AA^A D

Type	General(G), Ex-proof(N)												
Size code	202				204				205				
Size	25(1)				40(1.5)				50(2)				
Lining code	A, U				A, U				A, U				
Process Connection	J1	J2	A1	A2	D2	D4	J1	J2	A1	A2	D2	D4	
Height	H	226 (8.9)	217 (8.5)	225 (8.9)	221 (8.7)	221 (8.7)	244 (9.6)	237 (9.3)	251 (9.9)	248 (9.8)	245 (9.6)	255 (10.0)	
Height	H1	140 (5.5)	140 (5.5)	131 (5.2)	135 (5.3)	135 (5.3)	158 (6.2)	158 (6.2)	151 (5.9)	165 (6.5)	163 (6.4)	163 (6.4)	
Height	H2	77(3.0)**						87.5(3.4)**				94.5(3.7)**	
Outer dia.	øD	125 (4.9)	125 (4.9)	108 (4.3)	124 (4.9)	115 (4.5)	140 (5.5)	140 (5.5)	127 (5.0)	155 (6.1)	150 (5.9)	150 (5.9)	
Thickness	T**	21(0.8) to 26(1.1)	23(0.9) to 28(1.1)	21(0.8) to 28(1.1)	25(1) to 31(1.2)	22(0.9) to 28(1.1)	24(0.9) to 30(1.2)	23(0.9) to 30(1.2)	25(1) to 31(1.2)	28(1.1) to 34(1.3)	22(0.9) to 29(1.1)	24(0.9) to 30(1.2)	
Pitch circle dia.	øC	90 (3.54)	90 (3.54)	79 (3.1)	89 (3.50)	85 (3.35)	105 (4.13)	105 (4.13)	99 (3.90)	114 (4.49)	110 (4.33)	110 (4.33)	
Hole dia.	øh	19 (0.75)	19 (0.75)	18 (0.63)	19 (0.75)	14 (0.55)	19 (0.75)	19 (0.75)	16 (0.63)	22 (0.87)	18 (0.71)	18 (0.71)	
Number of holes	N	4	4	4	4	4	4	4	4	4	4	4	
Weight kg(lb)		5.2 (11.4)	5.5 (12.1)	4.6 (10.1)	5.6 (12.3)	5.1 (11.2)	7.4 (16.3)	7.7 (16.9)	7.0 (15.4)	9.2 (20.2)	8.0 (18.5)	8.0 (18.5)	

Process connection : J1: JIS10K J2: JIS20K A1: ANSI 150 A2: ANSI 300 D2: DIN PN16 D4: DIN PN40
 Lining code A : PFA Lining
 U : Polyurethane lining
 F21-2.eps

- * The face-to-face length is longer by approx.22mm(0.89 in.) for earth ring P,T.
- ** The thickness(T)is longer by approx.11mm(0.43 in.) for earth ring P,T.
- ** The face-to-face length is shorter by approx. 6mm(0.24 in.) for non earth ring type.
- ** The thickness (T) is shorter by approx. 3mm(0.12 in.) for non earth ring type.
- * The face-to-face length is longer by approx.2mm(0.08 in.) for optional code/FRG.
- ** The thickness(T)is longer by approx.1mm(0.04 in.) for optional code/FRG.
- *** The height marked as *** is shorter by 3mm(0.12 in.) for ex-proof type.

F20-3.EPS

80 and 100mm(3 and 4in.) Flange Type

Unit: mm
(approx. inch)

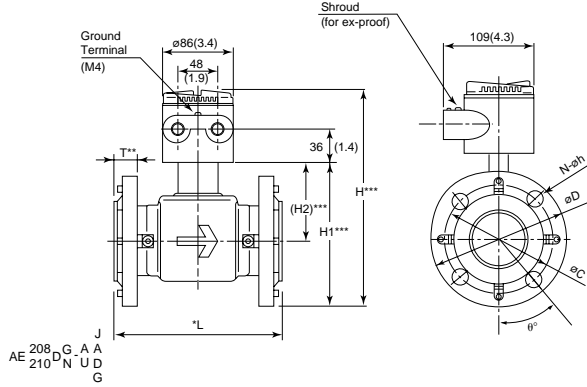

- * The face-to-face length is longer by approx.22mm(0.89 in.) for earth ring P.T.
- ** The thickness(T) is longer by approx. 11mm(0.43 in.)for earth ring P.T.
- * The face-to-face length is shorter by approx. 6mm(0.24 in.) for non earth ring type.
- ** The thickness(T) is shorter by approx. 3mm(0.12 in.) for non earth ring type.
- * The face-to-face length is longer by approx.2mm(0.08 in.) for optional code/FRG.
- ** The thickness(T) is longer by approx. 1mm(0.04 in.) for optional code/FRG.
- *** The height is shorter by 2.5mm(0.1 in.)for ex-proof type.

Type	General(G), Ex-proof(N)														
Size code	208							210							
Size	80(3)							100(4)							
Lining code	A(PFA), U(Polyurethane)														
Process Connection	J1	J2	A1	A2	D2	G1	J1	J2	A1	A2	D2	G1	J1	J2	
Height	H***	288(11.3)***	296(11.7)***	291(11.4)***	300(11.8)***	296(11.7)***	301(11.9)***	324(12.8)***	331(13.0)***	333(13.1)***	346(13.6)***	328(13.0)***	338(13.3)***	338(13.3)***	338(13.3)***
Height	H1***	202(8.0)***	210(8.3)***	205(8.1)***	214(8.4)***	210(8.3)***	215(8.5)***	238(9.4)***	245(9.6)***	247(9.7)***	260(10.2)***	243(9.6)***	252(9.9)***	252(9.9)***	252(9.9)***
Height	H2***	109.5(4.3)***													
Height	H2***	132.5(5.2)***													
Outer dia.	øD	185(7.2)	200(7.9)	191(7.5)	210(8.3)	200(7.9)	211(8.3)	210(8.3)	225(8.9)	229(9.1)	254(10)	220(8.7)	238(9.4)	238(9.4)	238(9.4)
Thickness	T**	25(1)	29(1.1)	31(1.2)	36(1.4)	26(1)	25(1)	25(1)	31(1.2)	31(1.2)	39(1.5)	26(1)	25(1)	31(1.2)	31(1.2)
Pitch circle dia.	øC	150(5.1)	160(6.3)	152(6.0)	168(6.6)	160(6.3)	168(6.6)	175(6.9)	185(7.3)	191(7.5)	200(7.9)	180(7.1)	195(7.7)	195(7.7)	195(7.7)
Hole dia.	øh	19(0.7)	23(0.9)	19(0.7)	22(0.9)	18(0.7)	19(0.7)	19(0.7)	23(0.9)	19(0.7)	22(0.9)	18(0.7)	19(0.7)	19(0.7)	19(0.7)
Number of holes	N	8	8	4	8	8	4	8	8	8	8	8	8	8	4
Bolt hole pitch	ø°	22.5	22.5	45	22.5	22.5	45	22.5	22.5	22.5	22.5	22.5	22.5	22.5	19
Face-to-face	L*	200(7.9)*													
Weight kg(lb)		13(28.6)	15(33.0)	15.3(33.7)	18.3(40.3)	15(33.1)	15.5(34.2)	21.0(46.3)	24.2(53.4)	25.0(55.1)	32.4(71.4)	22.7(50.1)	24.1(53.1)	24.1(53.1)	24.1(53.1)

F22.EPS

Process connection : J1 ; JIS10K J2 ; JIS20K A1 ; ANSI 150 A2 ; ANSI 300 D2 ; DIN PN16 G1 ; JIS F12

150 and 200mm(6 and 8in.) Flange Type

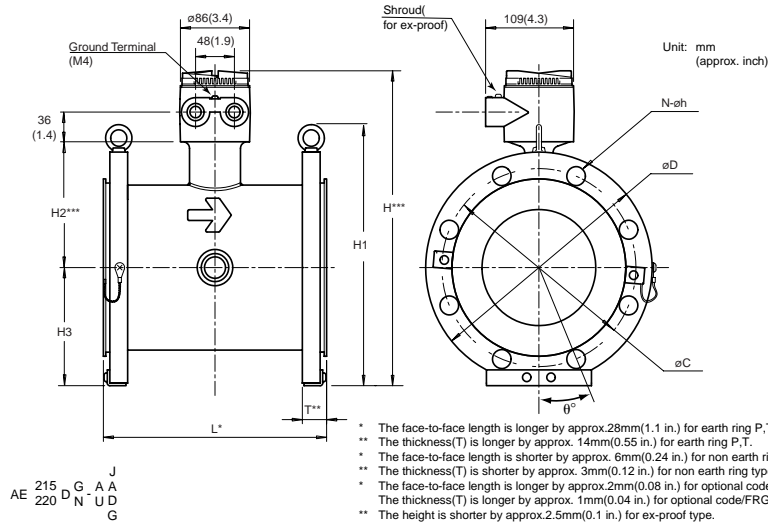

- * The face-to-face length is longer by approx.28mm(1.1 in.) for earth ring P.T.
- ** The thickness(T) is longer by approx. 14mm(0.55 in.) for earth ring P.T.
- * The face-to-face length is shorter by approx. 6mm(0.24 in.) for non earth ring type.
- ** The thickness(T) is shorter by approx. 3mm(0.12 in.) for non earth ring type.
- * The face-to-face length is longer by approx.2mm(0.08 in.) for optional code/FRG.
- ** The thickness(T) is longer by approx. 1mm(0.04 in.) for optional code/FRG.
- *** The height is shorter by approx.2.5mm(0.1 in.) for ex-proof type.

Type	General(G), Ex-proof(N)														
Size code	215							220							
Size	150(6)							200(8)							
Lining code	A(PFA), U(Polyurethane)														
Process connection	J1	G1	A1	J2	A2	D2	J1	G1	A1	J2	A2	D1	D2	J1	
Face-to-face	L	270(10.6)*													
Face-to-face	L	340(13.4)*													
Outer dia.	øD	280(11)	290(11.4)	279(11.0)	305(12)	318(12.5)	285(11.2)	330(13)	342(13.5)	343(13.5)	350(13.8)	381(15.0)	340(13.4)	340(13.4)	340(13.4)
Height	H***	382(15)***	387(15.2)***	381(15.0)***	394(15.5)***	401(15.8)***	384(15.1)***	432(17.0)***	438(17.2)***	438(17.3)***	442(17.4)***	457(18.0)***	437(17.2)***	437(17.2)***	437(17.2)***
Height	H1	317(12.5)	327(12.9)	316(12.4)	342(13.4)	354(13.9)	322(12.7)	367(14.4)	379(14.9)	379(14.9)	387(15.2)	418(16.4)	377(14.8)	377(14.8)	377(14.8)
Height	H2***	152.5(6.0)***													
Height	H2***	177.5(7.0)***													
Height	H3	143(5.6)	148(5.9)	143(5.6)	156(6.1)	162(6.4)	148(5.7)	168(6.6)	174(6.9)	175(6.9)	178(7.0)	194(7.6)	173(6.8)	173(6.8)	173(6.8)
Pitch circle dia.	øC	240(9.4)	247(9.7)	241(9.5)	260(10.2)	270(10.6)	240(9.4)	290(11.4)	299(11.8)	298(11.7)	305(12)	330(10.6)	295(11.6)	295(11.6)	295(11.6)
Number of holes	N	8	6	8	12	12	8	12	8	8	12	12	8	12	12
Bolt hole pitch	ø°	22.5	30	22.5	15	15	22.5	15	22.5	22.5	15	15	22.5	15	22.5
Hole dia.	øh	23(0.9)	19(0.7)	23(0.9)	25(1)	22(0.9)	22(0.9)	23(0.9)	19(0.9)	23(0.9)	25(1.0)	25(1.0)	22(0.9)	22(0.9)	22(0.9)
Thickness(A)	T**	30(1.2)***	30(1.2)***	33.4(1.3)***	36(1.4)***	44.5(1.8)***	30(1.2)***	30(1.2)***	32(1.3)***	36.4(1.4)***	38(1.5)***	48(1.9)***	32(1.3)***	32(1.3)***	32(1.3)***
Thickness(U)	T**	31(1.2)***	31(1.2)***	34.4(1.4)***	37(1.5)***	45.5(1.8)***	31(1.2)***	31(1.2)***	33(1.3)***	37.4(1.5)***	39(1.5)***	50(12.0)***	33(1.3)***	33(1.3)***	33(1.3)***
Weight(General) kg(lb)		29(63.9)	31(68.3)	31(68.3)	37(81.6)	48(105.8)	31(68.3)	41(90.2)	46(101.2)	49(107.8)	52(114.4)	73(160.6)	45(99.2)	46(101.2)	46(101.2)
Weight(Ex-proof) kg(lb)		32(70.6)	34(75.0)	34(75.0)	40(88.2)	51(112.5)	34(75.0)	46(101.4)	51(112.5)	54(119.1)	57(125.7)	78(172.0)	50(110.3)	51(112.5)	51(112.5)

F23.EPS

Process connection : J1 ; JIS10K J2 ; JIS20K A1 ; ANSI 150 A2 ; ANSI 300 D1 ; DIN PN10 D2 ; DIN PN16 G ; JIS F12

AE325DG/N-J/G/A/D, AE330DG/N-J/G/A/D, AE335DG/N-J/G/A/D, AE340DG/N-J/G/A/D Remote Type Magnetic Flow Tube (Flange Type)

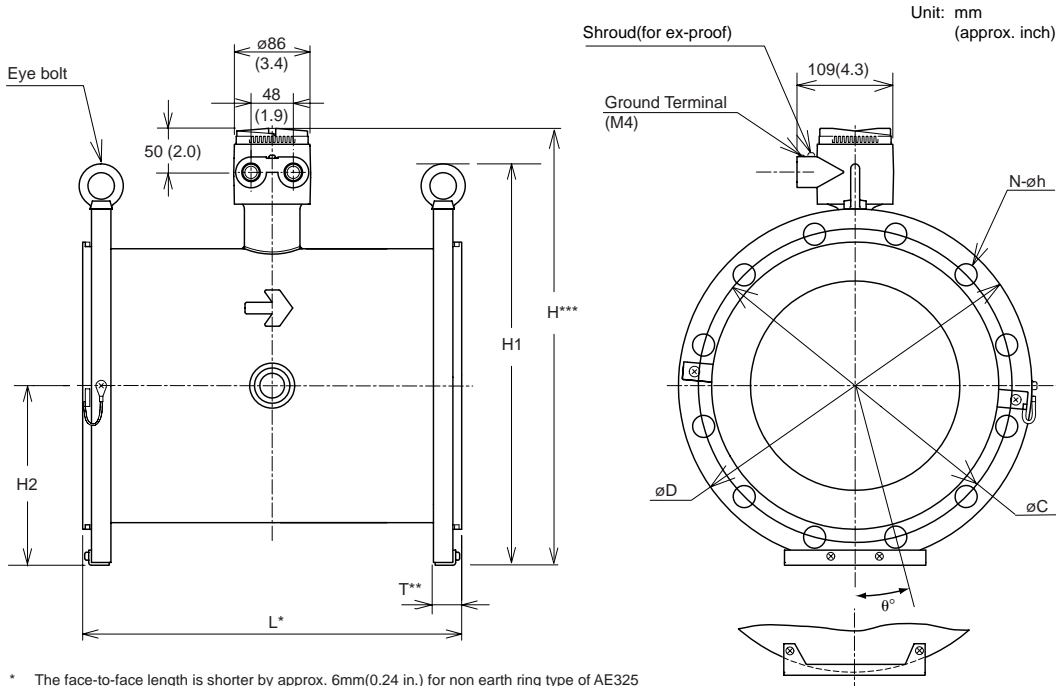

- * The face-to-face length is shorter by approx. 6mm(0.24 in.) for non earth ring type of AE325 and AE330, by approx. 10mm(0.39 in.) for non earth ring type of AE335 and AE340.
- ** The thickness(T) is shorter by approx. 3mm(0.12 in.) for non earth ring type of AE325 and AE330, by approx. 5mm(0.20 in.) for non earth ring type of AE335 and AE340.
- *** The height(H) is shorter by approx. 2mm(0.08 in.) for ex-proof type.

for AE330, AE335, AE340

Type	General(G), Ex-proof(N)				
	325	330	335	340	
Size code	325	330	335	340	
Size	250	300	350	400	
Lining code	A(PFA), U(Polyurethane)				
Face-to-face	L*	430(16.9)	500(19.7)	550(21.7)	600(23.6)
Eye bolt hole dia.	e	30(1.2)	30(1.2)	35(1.4)	35(1.4)
Height	H***	497(19.6)	544(21.4)	587(23.1)	650(25.6)
	H1	454(17.9)	499(19.7)	553(21.8)	623(24.5)
H2		203(7.9)	226(9.0)	248(9.8)	283(11.1)
Outer dia.	øD	400(15.8)	445(17.5)	490(19.3)	560(22.0)
Pitch circle dia.	øC	355(14.0)	400(15.8)	445(17.5)	510(20.1)
Number of holes	N	12	16	16	16
Bolt hole pitch	θ°	15	11.25	11.25	11.25
Hole dia.	øh	25(1.0)	25(1.0)	25(1.0)	27(1.1)
Thickness(A)	T**	32(1.3)	34(1.3)	36(1.4)	38(1.5)
Thickness(U)	T**	33(1.3)	35(1.4)	37(1.4)	39(1.5)
Weight (General) kg(lb)		64(141.1)	81(178.6)	94(207.2)	122(269.0)
Weight (Ex-proof) kg(lb)		68(149.9)	85(187.4)	100(220.5)	129(284.4)
Height	H***	512(20.2)	561(22.1)	-	-
	H1	484(19.1)	534(21.0)	-	-
H2		218(8.6)	243(9.6)	-	-
Outer dia.	øD	430(16.9)	480(18.9)	-	-
Pitch circle dia.	øC	380(15.0)	430(16.9)	-	-
Number of holes	N	12	16	-	-
Bolt hole pitch	θ°	15	11.25	-	-
Hole dia.	øh	27(1.1)	27(1.1)	-	-
Thickness(A)	T**	42(1.7)	44(1.7)	-	-
Thickness(U)	T**	43(1.7)	45(1.8)	-	-
Weight (General) kg(lb)		67(147.7)	85(187.4)	-	-
Weight (Ex-proof) kg(lb)		71(156.5)	89(196.2)	-	-
Height	H***	502(19.8)	553(21.8)	607(23.9)	661(26.0)
	H1	464(18.3)	518(20.4)	593(23.4)	645(25.4)
H2		208(8.2)	235(9.3)	268(10.6)	294(11.6)
Outer dia.	øD	410(16.1)	464(18.3)	530(20.9)	582(22.9)
Pitch circle dia.	øC	360(14.2)	414(16.3)	472(18.6)	524(20.6)
Number of holes	N	8	10	10	12
Bolt hole pitch	θ°	22.5	18	18	15
Hole dia.	øh	23(0.9)	23(0.9)	25(1.0)	25(1.0)
Thickness(A)	T**	32(1.3)	34(1.3)	36(1.4)	36(1.4)
Thickness(U)	T**	33(1.3)	35(1.4)	37(1.5)	37(1.5)
Weight (General) kg(lb)		64(141.1)	81(178.6)	94(207.2)	122(269.0)
Weight (Ex-proof) kg(lb)		68(149.9)	85(187.4)	100(220.5)	129(284.4)
Height	H***	500(19.7)	551(21.7)	-	-
	H1	459(18.1)	514(20.2)	-	-
H2		206(8.1)	233(9.2)	-	-
Outer dia.	øD	405(15.9)	460(18.1)	-	-
Pitch circle dia.	øC	355(14.0)	410(16.1)	-	-
Number of holes	N	12	12	-	-
Bolt hole pitch	θ°	15	15	-	-
Hole dia.	øh	22(0.9)	22(0.9)	-	-
Thickness(A)	T**	34(1.3)	36(1.4)	-	-
Thickness(U)	T**	35(1.4)	37(1.5)	-	-
Weight (General) kg(lb)		65(143.3)	82(180.8)	-	-
Weight (Ex-proof) kg(lb)		69(152.1)	86(189.6)	-	-

F24.EPS

Earth Ring Inside Diameter

Unit: mm(inch)

Size	PFA/Polyurethane lining	Ceramic lining
2.5(0.1)	φ15(0.6)	—
5(0.2)	φ15(0.6)	—
10(1.4)	φ15(0.6)	—
15(0.5)	φ15(0.6)	φ15(0.6)
25(1)	φ27(1.1)	φ27(1.1)
40(1.5)	φ40(1.6)	φ40(1.6)
50(2)	φ52(2.1)	φ52(2.1)
65(2.5)	φ63.5(2.5)	—
80(3)	φ81(3.2)	φ81(3.2)
100(4)	φ98(3.9)	φ98(3.9)
125(5)	φ118.6(4.7)	—
150(6)	φ140.7(5.6)	φ144(5.7)
200(8)	φ188.9(7.5)	φ192(7.6)
250(10)	φ239.1(9.5)	—
300(12)	φ291.3(11.5)	—
350(14)	φ323.4(12.8)	—
400(16)	φ373.5(14.8)	—

* Please ensure that the I.D. of the gasket does not protrude into the I.D. of the Earth Ring. (This dimension is also applied to when no earth ring is used.)

T20.EPS

Magnetic Flow Converter AE14

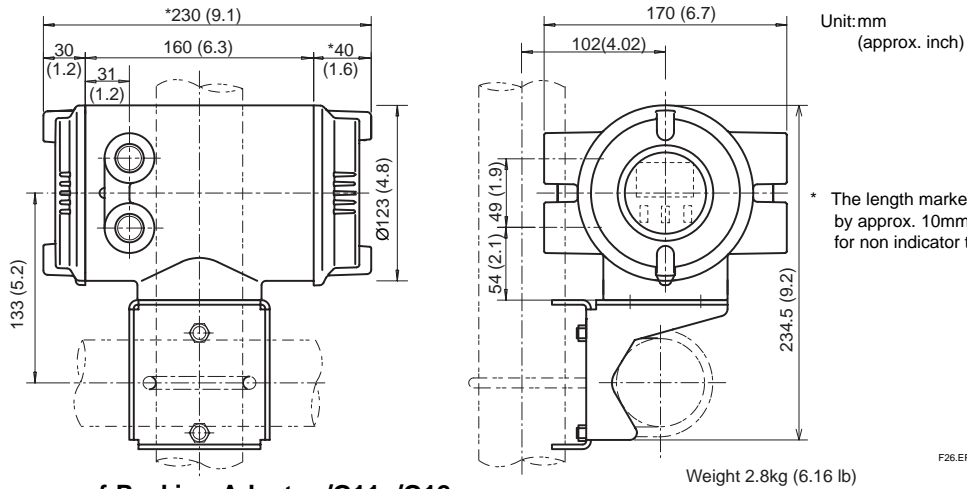

TIIS(JIS) Flameproof Packing Adapter /G11, /G12

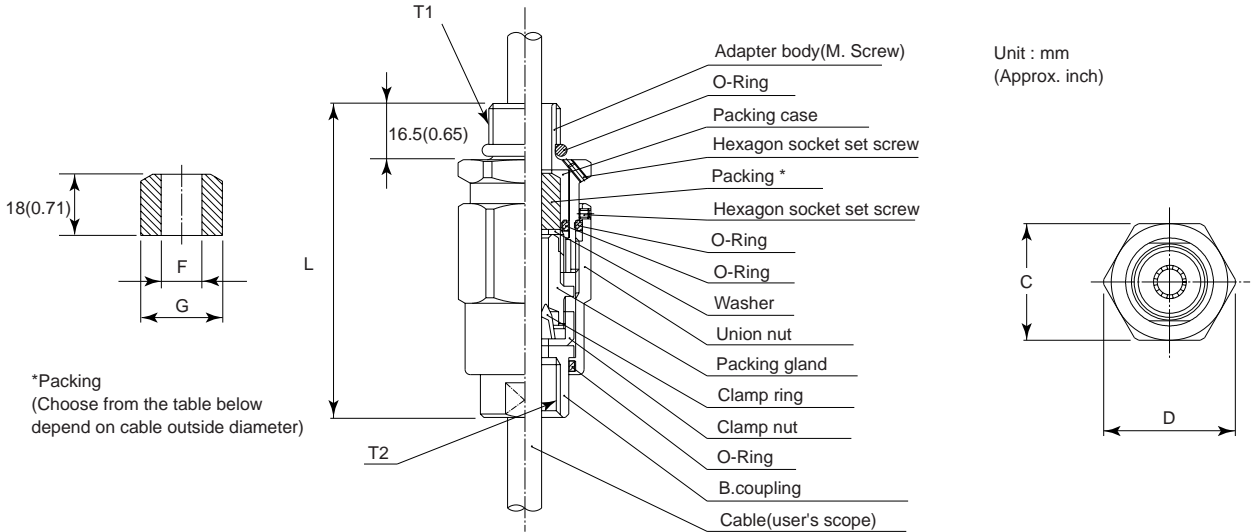

Dimension					Cable outer diameter	Packing diameter		Identification mark	Weight kg (lb)
T1	T2	C	D	L		F	G		
G 1/2	G 1/2	35 (1.38)	39 (1.54)	94.5 (3.72)	φ8.0 to φ10.0 (0.31 to 0.39)	φ10.0(0.39)	φ20.0	16 8-10	0.26
					φ10.0 to φ12.0 (0.39 to 0.47)	φ12.0(0.47)	(0.79)		

Sanitary, Integral Magnetic Flowmeter AE200MH

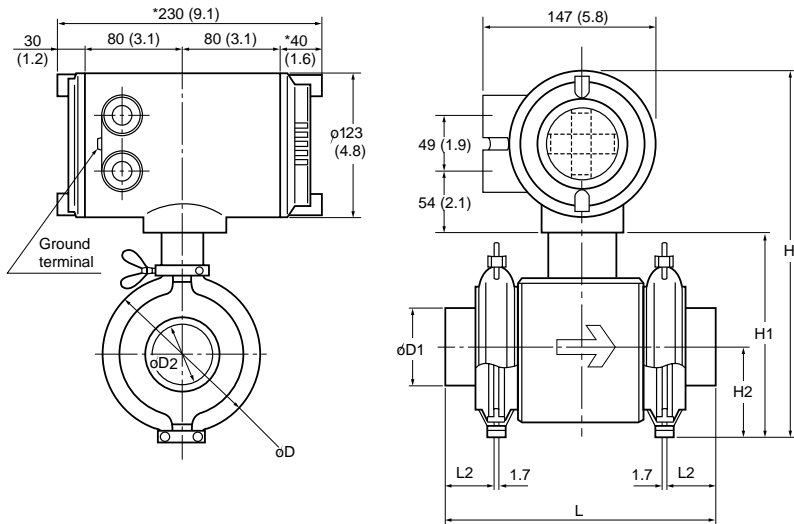

Unit: mm
(approx. inch)

Size code	202	204	205	206	208	210
Size	25(1)	40(1.5)	50(2)	65(2.5)	80(3)	100(4)
Lining	PFA					
Face-to-face length	L	176(6.9)	186(7.3)	206(8.1)	206(8.1)	246(9.7)
Ferrule length	L2	43(1.7)	41(1.6)	44(1.7)	44(1.7)	44(1.7)
Ferrule outer diameter	D1	25(1.0)	38(1.5)	51(2.0)	64(2.5)	76(3.0)
Ferrule inner diameter	D2	23(0.9)	36(1.4)	48(1.9)	60(2.4)	72(2.8)
Clamp O.D.	D	74(2.9)	89.5(3.5)	103(4.1)	122(4.8)	131(5.2)
Height	H	266(10.5)	289(11.4)	301(11.9)	314(12.4)	340(13.4)
Height	H1	126(5.0)	149(5.8)	161(6.3)	174(6.9)	200(7.9)
Height	H2	49(1.9)	61(2.4)	67(2.6)	70(2.8)	81(3.2)
Weight	kg (lb)	5.8(12.8)	6.9(15.2)	8.3(18.3)	9.9(21.8)	12.2(26.9)

* The length marked as * is shorter by approx. 10mm(0.4 in.) for non indicator type.

F27.EPS

Sanitary, Remote Magnetic Flow Tube AE200DH

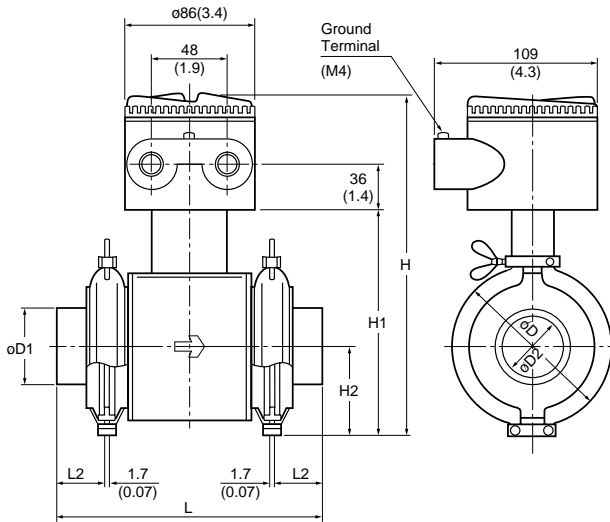

Unit: mm
(approx. inch)

Type	Sanitary(H)					
Size code	202	204	205	206	208	210
Size	25(1)	40(1.5)	50(2)	65(2.5)	80(3)	100(4)
Lining	PFA lining					
Face-to-face length	L	176(6.9)	186(7.3)	206(8.1)	206(8.1)	246(9.7)
Ferrule length	L2	43(1.7)	41(1.6)	44(1.7)	44(1.7)	44(1.7)
Ferrule outer dia.	D1	25(1.0)	38(1.5)	51(2.0)	64(2.5)	76(3.0)
Ferrule inner dia.	D2	23(0.9)	36(1.4)	48(1.9)	60(2.4)	72(2.8)
Clamp outer dia.	D	74(2.9)	90(3.5)	103(4.1)	122(4.8)	131(5.2)
Height	H	212(8.3)	235(9.3)	248(9.8)	260(10.2)	277(10.9)
Height	H1	126(5.0)	149(5.8)	162(6.4)	174(6.9)	191(7.5)
Height	H2	49(1.7)	61(2.4)	67(2.6)	70(2.8)	81(3.2)
Weight	kg(lb)	3.5(7.7)	4.6(10.1)	6.0(13.2)	7.6(16.8)	9.9(21.8)

F28.EPS

■ SIZING DATA

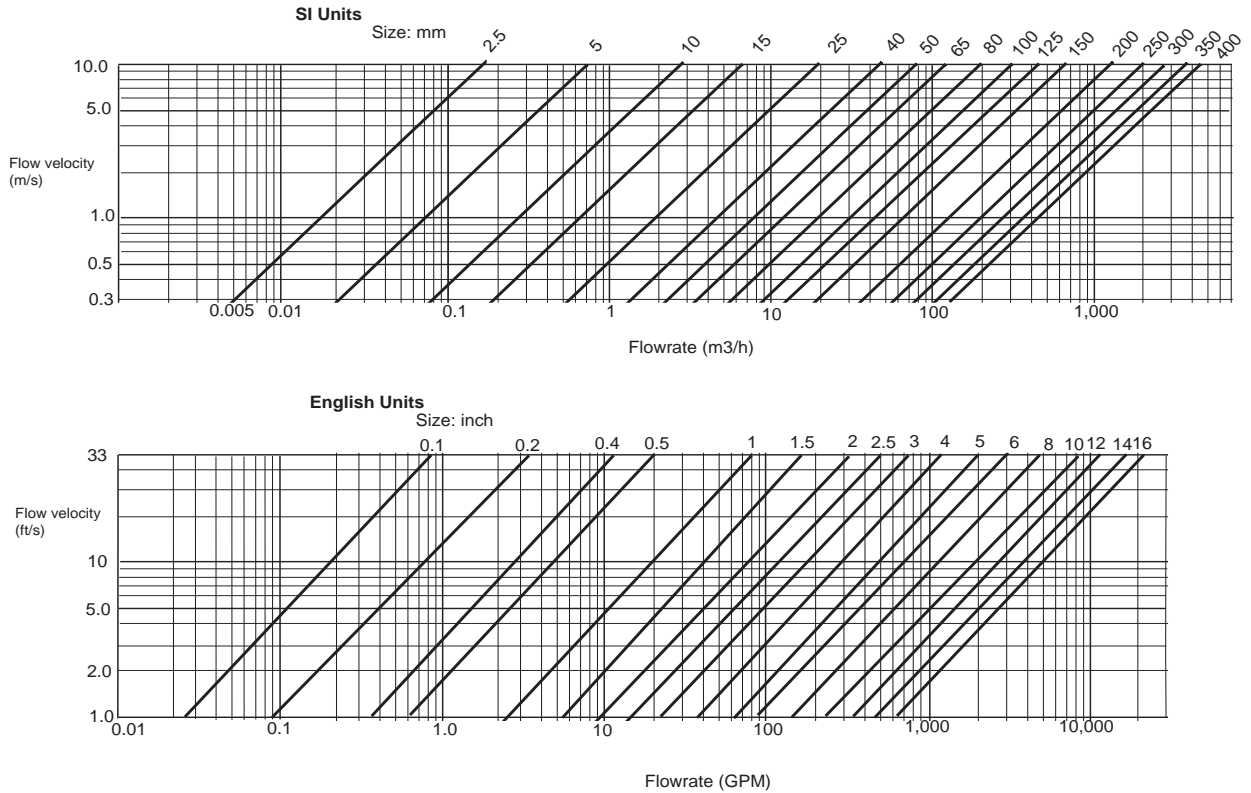

* Measurable flow velocity is from 0 m/s.

F29.EPS

■ GASKET

Please use compressed non-asbestos fiber gasket, PTFE gasket or the gasket which has equal elasticity. In case of optional code/FRG, please use rubber gasket or others which has equal elasticity.

=== ORDERING INFORMATION ===

1. Model, specification and optional codes.
 2. Fluid name.
 3. Parameter setting. (Only when necessary)
 - (1) Flow rate span (at 100% output)
Example: Volume/time unit
 - (2) Totalizing pulse units
Example: Volume/pulse, Pulse/time unit
 - (3) Transmission pulse units
Example: Volume/pulse, Pulse/time unit
 4. Tag number. (Only when necessary)
8 characters maximum for parameter
16 characters maximum for tag plate and certificate
- * Please refer to GS01E07F01-00E for Fieldbus communication type.

=== RELATED INSTRUMENTS ===

- Related Products
- Calibrator for magnetic flowmeter (AM012) GS 01E06K02-00E
 - BT200 Brain Terminal GS 1C0A11-E
 - Fieldbus communication type magnetic flowmeterGS 01E07F01-00E