

## GTD-5000 Sampling Oxygen & Toxic Gas Detector

| Fast response of toxic gases & Oxygen leakage with a high efficient pump inside | Self diagnosis function with built-in Microprocessor | Easy replacement with a cartridge type sensor | Digital flow sensor to maintain regular flow rate | Stable quality and proved detection principle for service life | Superior performance for detecting toxic gases below TLV | Fine LCD display for showing various information | 4-digit digital gas concentration display | 4-20mA (Current source or Sink) output signal | Easy configuration of monitoring system by RS-485 Modbus communication or PoE | 2-stage alarm, 1-trouble display and relay contact output | 3-Wire Type | Calibration and maintenance by one-man |

### IMAGE



### DIMENSION (Unit : mm)

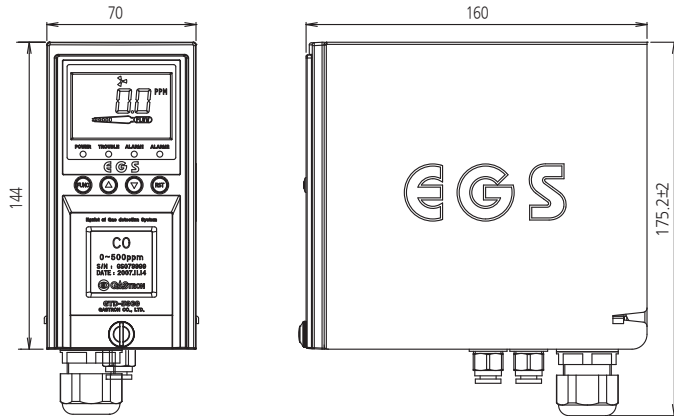

### ACCESSORIES



Micro Filter



Mounting Bracket



PY-1000



Sensor Cartridge

### SPECIFICATION

※ Specifications are subject to be changed without prior notice.

INTELLIGENT & SAMPLING TYPE OXYGEN & TOXIC GAS DETECTOR	
Model	GTD-5000
Measuring gas	O <sub>2</sub> / Toxic gases(CO, Cl <sub>2</sub> , NH <sub>3</sub> & etc)
Measuring type	Auto Sampling type
Measuring method	Semiconductor cell, Electrochemical cell
Measuring range	Refer to Toxic Gas Measuring Range
Response time	< 45sec / 90% scale
Accuracy	±3% / Full scale
Parameter control	Front switch (calibration, maintenance, alarm setting)
Operation mode display	4-LED (Power, 2-stage alarm, 1-trouble)
Measuring value display	LCD Display(4-Digit)
Alarm signal output	2A@30VDC, 0.5A@125VAC (resistive load) / 3-SPST relay contact(2stage alarm, 1 trouble)
Output signal	4 - 20mA DC    RS-485 Modbus(Optional) / PoE(Power over Ethernet)(Option)
Sampling method	Diaphragm Pump
Sampling line	OD 1/4" (Standard)
Flow rate	0 ~ 1000 ml/min max
Conduit connection	Cable gland(PG-16)
Mounting type	Wall mount
Operating temperature	-20°C ~ +60°C
Operating humidity	5 to 99% RH (Non-condensing)
Material	Front(Poly carbonate), Sides(Steel)
Dimensions	Standard type : 70(W) × 144(H) × 160(D) mm    Pyrolyzer type(PY-1000) : 70(W) × 242.5(H) × 160(D) mm
Weight	Standard type : 2.5kg    GTD-5000 & PY-1000 : 4.05kg
NOTE 1	Current consumed by Pyrolyzer(PY1000, PY2000) Unit
NOTE 2	DC 24V should be supplied if you want to use Pyrolyzer in case of using PoE power
CERTIFICATION	
CE / CPA	Refer to website