

GTD-5000F Explosion Proof Type Sampling Infrared Gas Detector

| Continuous detection of flammable, CO₂, CO and N₂O gas in explosion hazardous area with flame proof structure | State-of-the art infrared detection principle | Operation in non oxygen environment | Digital flow sensor to maintain regular flow rate | Fast response detection of gas leakage with a high efficient pump inside | Self diagnosis function with built-in Microprocessor | Fast response time(<6 sec) | Stable quality and proved detection principle for service life | Auto calibration and program setting with a magnet bar | 4-digit digital gas concentration display | 4-20mA (Current source or Sink) output signal | Easy configuration of monitoring system by RS-485 Modbus communication | 3-Wire Type | 2-stage alarm, 1-trouble display and relay contact output | Calibration and maintenance by one-man |

IMAGE

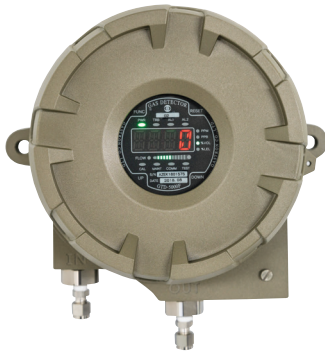

DIMENSION (Unit : mm)

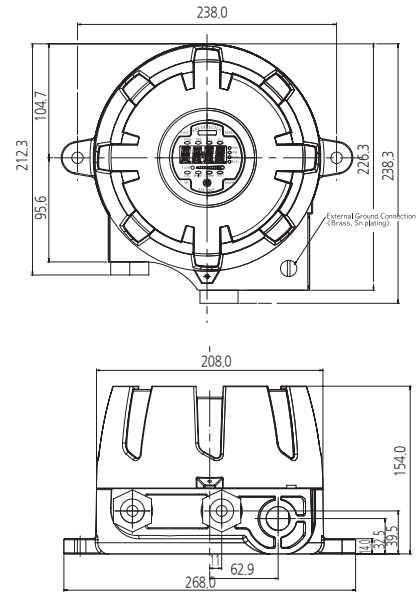

ACCESSORIES



Cable Gland



Male Connector



Micro Filter



Mounting Bracket

SPECIFICATION

※ Specifications are subject to be changed without prior notice.

EXPLOSION PROOF & SAMPLING TYPE INFRARED GAS DETECTOR				
Model	GTD-5000F			
Measuring gas	Hydrocarbon gases (LNG, LPG, Methane, Buthane & etc)		CO ₂	CO, N ₂ O
Measuring type	Auto Sampling type			
Measuring method	Infrared type			
Measruing range	0-100% LEL	0-5000ppm	0-100% Vol	0-5.0% Vol, 0-2.0% Vol, 0-4000ppm
Response time	< 6sec / 90% scale, < 3sec / 50% scale			
Accuracy	±3% / Full Scale			
Parameter control	Non intrusive control with a Magnet bar (calibration, maintenance, alarm setting)			
Operation mode display	Alarm / Trouble LED , Flow rate			
Measuring value display	FND Display(4-Digit)			
Alarm signal output	2A@30VDC, 0.5A@125VAC (resistive load) / 3-SPST relay contact(2stage alarm, 1 trouble)			
Output signal	Analog output : 4-20mA DC		Digital output : RS-485 Modbus(Optional)	
Sampling method	Diaphragm Pump			
Sampling line	OD 1/4 "(Standard)			
Flow rate	0 -2000 ml/min Max			
Conduit connection	Standard : PF 3/4"		Option : NPT 1/2", NPT3/4", M20 x 1.5P, M25 x 1.5P	
Mounting type	Wall mount			
Operating temperature	-40°C ~ +60°C			
Operating humidity	5 to 99% RH (Non-condensing)			
Material	ALDC			
Dimensions	226.3(W) × 154(H) × 238(D) mm			
Weight	5kg			
CERTIFICATION				
KCs	Ex d IIC T6		NEPSI	Ex d IIB+H2 T6, T5 Gb
ATEX / IECEx	Ex d IIB+H2 T6, T5 Gb		CE / KFI / KC / CPA	Refer to website